

# BearCat's Classic Crumb Rubber Asphalt Spreader Ground Tire Rubber (GTR) Trailer Mounted



## BearCat's Industry Leading Firsts \_\_\_\_\_

Full Cab Control

1-Foot Spray control

Internal Poppet Spray Valves

Computer Rate Control

Limit Switches on Wings

Double Fold Wings

All Electric Tack Truck

Self Contained Crumb Rubber Trailer

\_\_\_\_\_ *BearCat Mfg. Inc. "Innovation by Design"*



# Crumb Rubber / Ground Tire Rubber (GTR) Truck or Trailer With Two or Single Augers

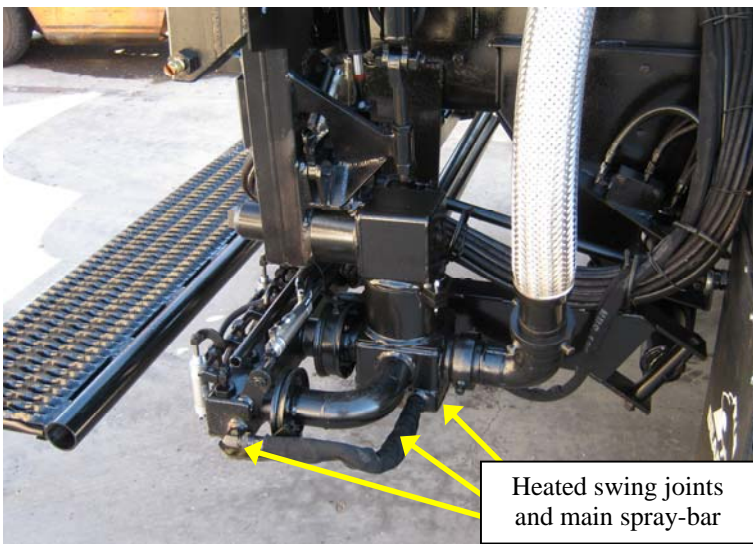
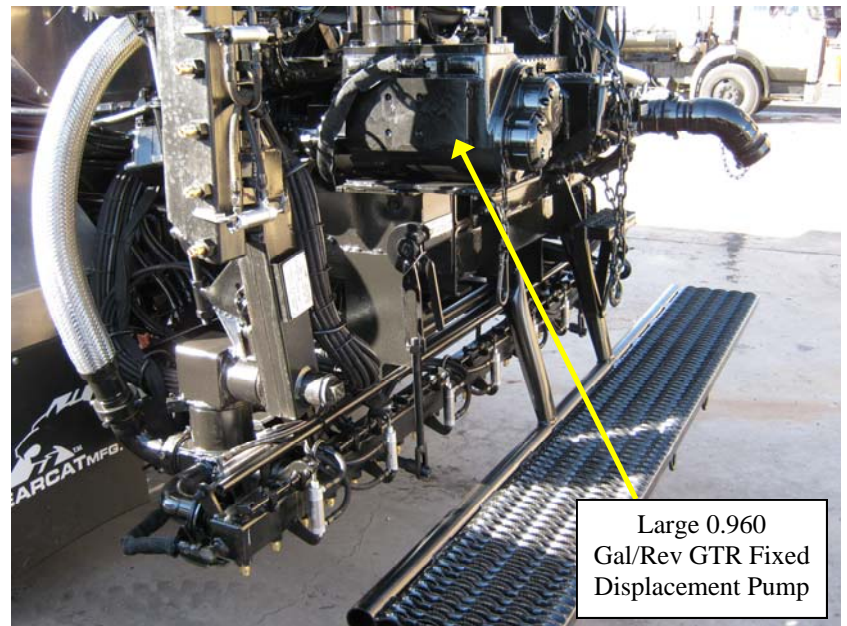
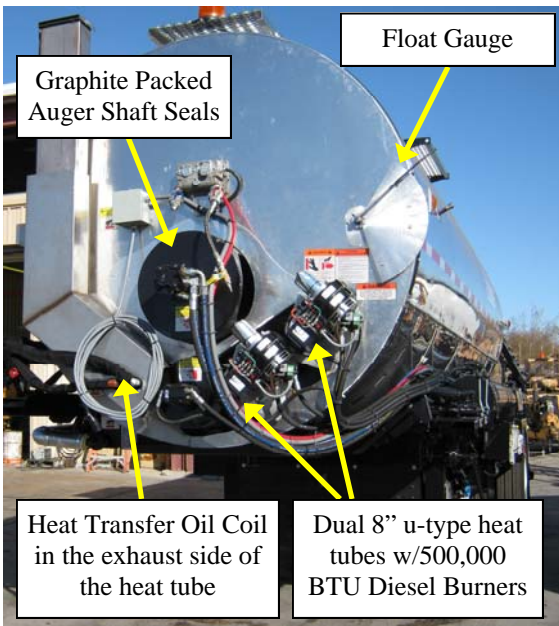
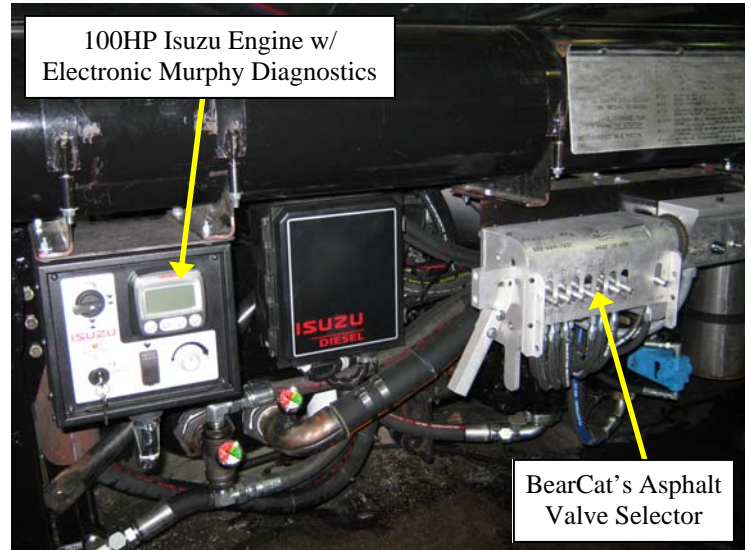
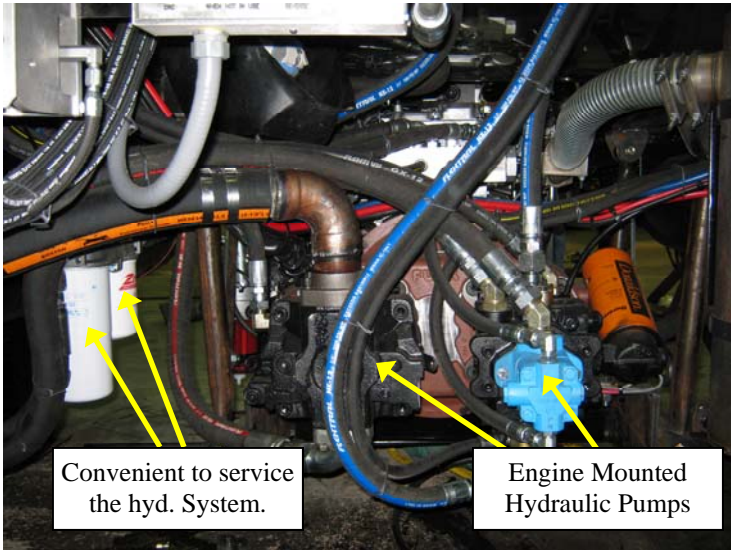

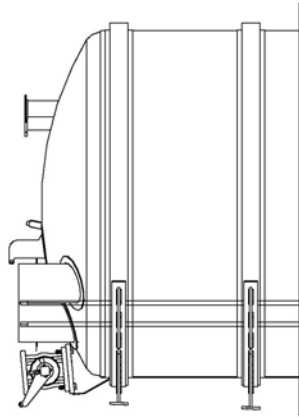
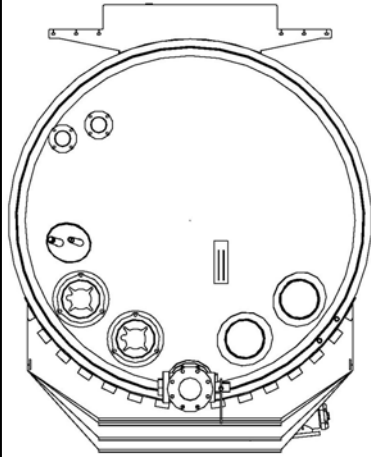
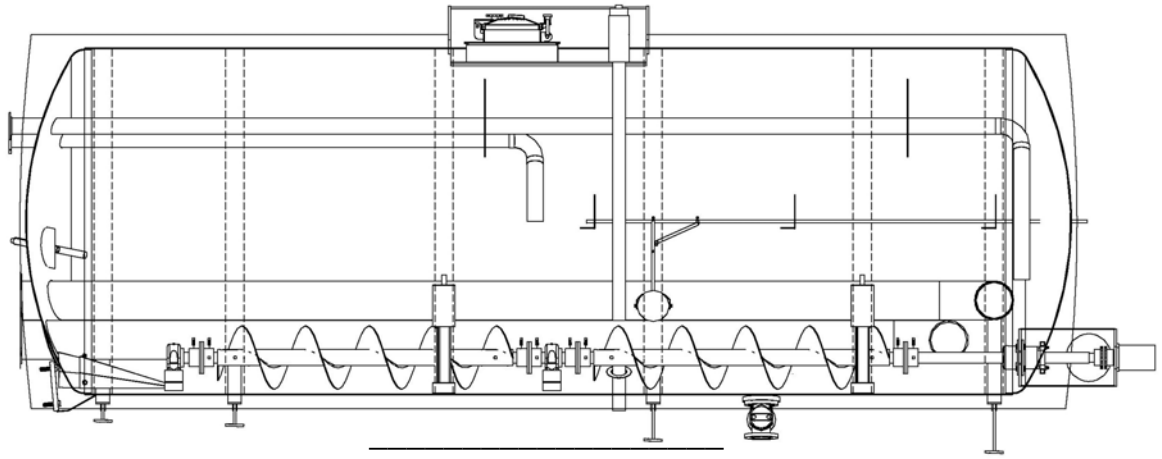
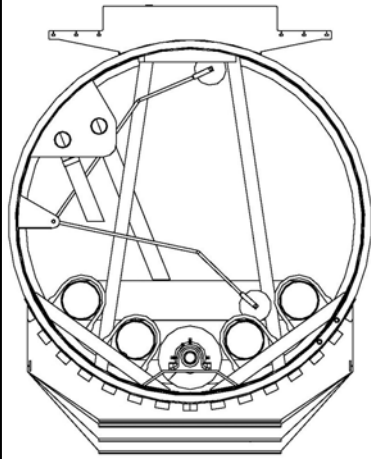

## GTR Single Auger Truck/Trailer Features

- Up to 3,800 Gallon (14,385 Liter) Tank.
- 14" (35.6 cm) reversible auger.
- Large auger support bearings.
- Clean bore design for smooth material flow while mixing.
- Two full length heat tubes (propane or diesel fired).
- Rolled exterior tank support rings.
- Choice of optional Hot Oil heat traced systems; to heat all asphalt valves, spray-bar and filter-screen housings.
- Large heated 5" (12.7 cm) tank valve.
- Heated side load valve for fast plant loading.
- **These trucks are designed to spread rubberized asphalt containing 15% or more of "Crumb Rubber" but can also spread conventional asphalt products.**

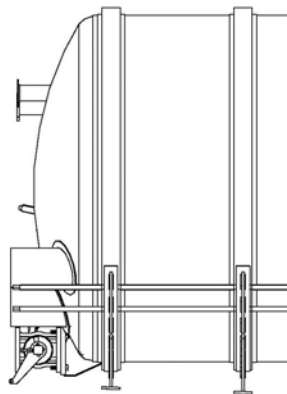
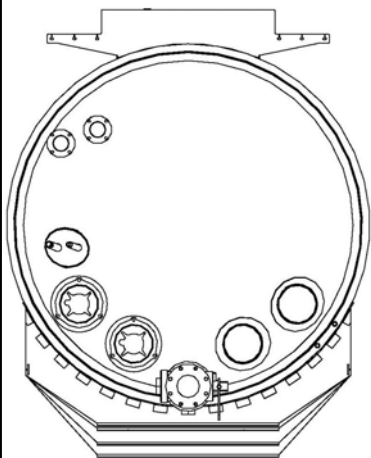
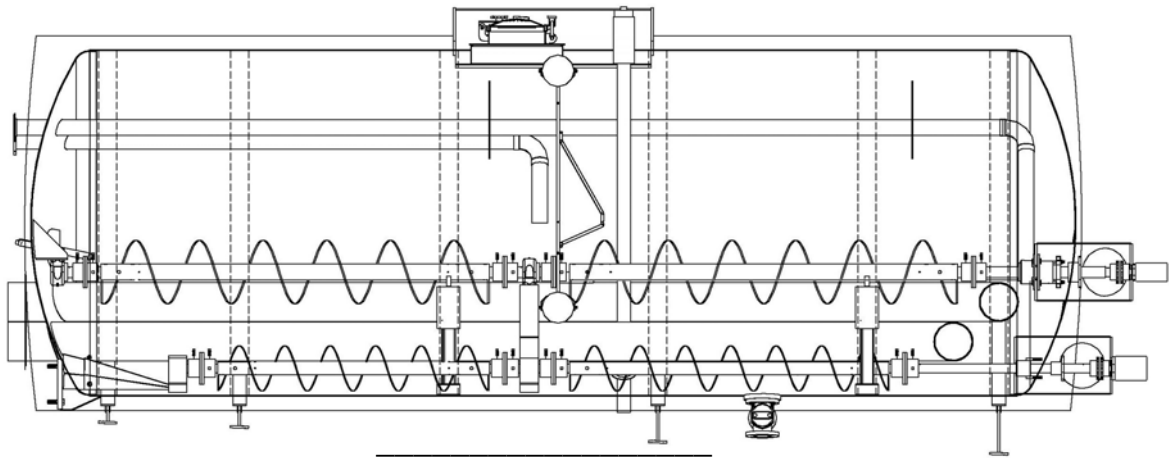
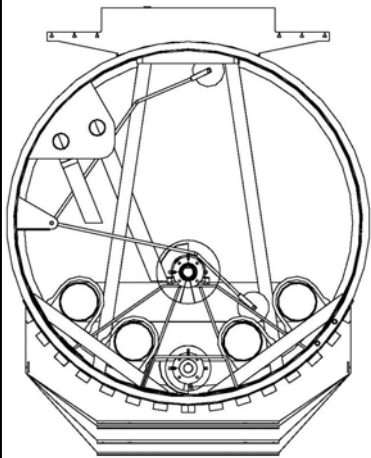

## GTR Two Auger Truck/Trailer Features

- Up to 3,800 Gallon (14,385 Liter) Tank.
- 14" (35.6 cm) reversible mixing auger, either pulls material to center of the tank or pushes material to each end of the tank.
- 10" reversible auger. To move material towards the tank valve.
- Large auger support bearings.
- Clean bore design for smooth material flow while mixing.
- Two full length heat tubes (propane or diesel fired).
- Rolled exterior tank support rings.
- Choice of optional Hot Oil heat traced systems; to heat all asphalt valves, spray-bar and filter-screen housings.
- Large heated 5" (12.7 cm) tank valve.
- Heated 3" (7.62 cm) side load valve for fast plant loading.

# Crumb Rubber / Ground Tire Rubber (GTR) Truck or Trailer With Two or Single Augers

## Rubber Trailer Specifications Single Auger

- Up to a 3,800 Gallon (14,385 Liter) Tank
- 14" (35.6 cm) flow auger, to move material to the rear tank valve.
- Auger bearings 2 11/16" (6.83 cm).
- 50HP Diesel Engine
- Two hole bell-housing mounted gear box for hydraulic pumps.
- Product pump drive system 75cc heavy duty hydrostatic piston pump driving a 200cc LSHT motor w/external loop flushing valve
- Product pump 0.960G/rev (3.64 L/rev)  
400GPM (1515 LPM) max
- Auxiliary pump 60cc open loop piston pump, used for the auger, cooling fan and hot oil circulating pump.
- Spray-bar and wing raise lower, spray-bar side shift functions supplied by a V10 vane pump
- Large capacity hydraulic cooler w/hydraulic fan
- CRC control, cab mounted for full spreading operation from drivers seat
- 16' (4.9 m) spray-bar w/1' (0.3 m) cuts
- 8' (2.5 m) main bar w/4' (1.25 m) single fold wings
- Large 4" (10 cm) intake plumbing.
- Large 5" (12.7 cm) heated tank valve.
- Large capacity suction strainer.
- Bar screen.
- Stainless steel bar feed hoses.
- Full circulating spray-bar.
- Optional HOT oil system for pump case, plumbing, spray-bar and valves
- Maximum operating temperature, 450°F (232° C) w/stainless hoses.
- Bearcat pneumatic valve selector
- Internal spray poppet valves  
Break away wings.
- Bearcat pneumatic valve selector.
- The same Bearcat CRC cab control system you have come to trust on the BC501 is used on the GTR spreader systems.
- Two 8" (20.5 cm) u-type heat tubes.
- Two 770,000BTU diesel burners.
- Optional two 403,400BTU propane burners.

## Rubber Trailer Specifications Two Auger

- Up to a 3,800 Gallon (14,385 Liter) Tank
- 10" (25.4 cm) flow auger, to move material to the rear tank valve.
- Bottom auger bearings 2" (5.1 cm)
- 14" (35.6 cm) reversible mixing auger w/2 11/16" bearings.
- Mixing auger bearings 2 11/16" (6.83 cm).
- 100HP Diesel Engine
- Two hole bell-housing mounted gear box for hydraulic pumps.
- Product pump drive system 75cc heavy duty hydrostatic piston pump driving a 200cc LSHT motor w/external loop flushing valve
- Product pump 0.960G/rev (3.64 L/rev)  
400GPM (1515 LPM) max
- Auxiliary pump 60cc open loop piston pump, used for the auger, cooling fan and hot oil circulating pump.
- Spray-bar and wing raise lower, spray-bar side shift functions supplied by a V10 vane pump
- Large capacity hydraulic cooler w/hydraulic fan
- CRC control, cab mounted for full spreading operation from drivers seat
- 16' (4.9 m) spray-bar w/1' (0.3 m) cuts
- 8' (2.5 m) main bar w/4' (1.25 m) single fold wings
- Large 4" (10 cm) intake plumbing.
- Large 5" (12.7 cm) heated tank valve.
- Large capacity suction strainer
- Bar screen
- Stainless steel bar feed hoses
- Full circulating spray-bar
- Optional HOT oil system for pump case, plumbing, spray-bar and valves
- Maximum operating temperature, 450°F (232° C) w/stainless hoses.
- Bearcat pneumatic valve selector
- Internal spray poppet valves  
Break away wings.
- Bearcat pneumatic valve selector.
- The same Bearcat CRC cab control system you have come to trust on the BC501 is used on the GTR spreader systems.
- Two 8" (20.5 cm) u-type heat tubes.
- Two 770,000BTU diesel burners.
- Optional two 403,400BTU propane burners.