

2013

INSTRUCTION MANUAL  
Model BC-502/CRC

**Computer-Controlled  
Liquid Asphalt Distributor**

Unit Serial Number: \_\_\_\_\_

FCAL # \_\_\_\_\_

GCAL # \_\_\_\_\_

Date of Service: \_\_\_\_\_

Customer: \_\_\_\_\_

Training Performed By: \_\_\_\_\_

I Have Received \_\_\_\_\_ Hours Training

Signature: \_\_\_\_\_

This manual describes the Model BC-502/CRC as it is normally delivered to the user, at the time the manual is prepared. Due to a continuing program of product improvement, changes may be made in equipment delivered at a later date. Every attempt is made to keep users fully informed of such changes. For the latest version of this manual, download and print:

[www.bearcatmfg.com/pdf/BC-502\(2013\)Manual.pdf](http://www.bearcatmfg.com/pdf/BC-502(2013)Manual.pdf)



# Warranty and claim procedures

## Limited Warranty

*BearCat Mfg., Inc. (here in after referred to as “BearCat”) extends to the original purchaser-user of its Model BC-502 Asphalt Distributor, the following warranty covering goods manufactured by BearCat, subject to the qualifications listed.*

*The warranty applies only when the product:*

- 1. Is properly used and maintained in accordance with BearCat instructions, governing agencies or associations.**
- 2. Is being operated under proper fuel and/or cargo characteristics.**
- 3. Is not subject to corrosive or abrasive atmosphere or materials.**
- 4. Has not been damaged through malice or ignorance.**
- 5. Has not been subject to flood, lightning, accidents, misuse, neglect or unauthorized modification, repair or service.**

*Parts replaced under this warranty are warranted only through the remaining time of the original warranty.*

*BearCat warrants that at the time of delivery, the product manufactured by BearCat and delivered new to the original purchaser-user shall be free from defects in material and workmanship for a period of one (1) year on the Asphalt Distributor and five (5) years on the Product Tank, after delivery when operated and maintained under normal use and service and in accordance with the written instructions provided by BearCat.*

Warranty Claims

*BearCat agrees at its option, to repair or replace F.O.B. Wickenburg, Arizona, any part acknowledged by BearCat to be defective when returned to BearCat; provided that:*

- 6. The defective part is returned transportation charges prepaid to BearCat for inspection.**
- 7. BearCat determines that the defective part had failed under the terms of the above warranty.**

**BEARCAT WILL NOT INSTALL AND WILL NOT PAY ANY INSTALLATION COST, TRANSPORTATION COST, TRAVEL TIME, MILEAGE, LABOR COSTS OR OTHER EXPENSES OF ANY DEFECTIVE PARTS REPLACED OR REPAIRED UNLESS THE USER HAS REACHED A PRIOR AGREEMENT WITH BEARCAT.**

*The user shall notify BearCat of any defect within this warranty no later than thirty (30) days after a defect is discovered.*

*No defective parts will be accepted for return or replacement without the written authorization of BearCat, or verbal authorization from the BearCat Service Department. Upon such authorization, the part should be returned within thirty (30) days to BearCat, shipping charges prepaid, at the following address:*

BearCat Mfg., Inc.

3650 Sabin Brown Road

Wickenburg, AZ 85390

Phone: (928) 684-7851

Fax: (928) 684-3241



## Exclusions

*The provisions of the foregoing warranty are BearCat's sole obligation and exclude all other warranties express or implied.*

*BearCat shall not be responsible for any loss, damage, incidental or consequential damages of any kind, whether based upon warranty, contract or negligence, arising concerning the sale, use, or repair of the product.*

*Components manufactured by any supplier other than BearCat shall bear only the warranty made by the manufacturer of that product.*

## Introduction

BearCat liquid asphalt distributors (Model BC-502/CRC) are designed and manufactured to ensure personnel safety when the equipment is operated properly and all safety precautions are strictly followed.

Persons responsible for the operation and field maintenance of the Model BC-502/CRC distributor should read this manual carefully before attempting to operate the equipment or performing any service or adjustment procedures on it.

NOTE: *BearCat Manufacturing assumes no liability for accident or injury incurred through improper use of this equipment.*

---

**WARNING:** BearCat equipment uses volatile materials at high temperatures and pressures. This equipment employs highly combustible or explosive fuels. Potentially life-threatening hazards may exist during equipment operation. Personnel must be trained and familiar with (Safety precautions) before operating BearCat equipment.

---

---

**WARNING:** Potentially life-threatening hazards may exist during equipment operation. Only qualified personnel should attempt to operate, service or make adjustments to the BearCat equipment.

---

---

**WARNING:** The materials used in the BC-502 are normally heated to 300° F to 400° F during application. Materials used at these temperatures can cause serious or fatal burns and can become explosive under certain conditions. Diesel Fuel used in the burners to heat these materials is highly flammable. Extreme care must be exercised at all times to ensure the safety of personnel working in proximity to these potentially hazardous conditions.

---



## Abbreviation/Definition Table

ABBREVIATION	DEFINITION
BTU	British Thermal Units
CCW	Counter Clockwise
CFM	Cubic Feet per Minute
CRC	Computerized Rate Control
CW	Clockwise
FCAL	Footage Calibration
FPM	Feet per Minute
GCAL	Gallons Calibration
GPM	Gallons per Minute
KgSM	Kilograms per Square Meter
LPM	Liters per Minute
LSM	Liters per Square Meter
MPM	Meters per Minute
PSI	Pounds per Square Inch
PSY	Pounds per Square Yard
PTO	Power Take Off
RPM	Revolutions per Minute
Wet Asphalt	Emulsified asphalt or containing water

**Table of Contents**

**3 WARRANTY AND CLAIM PROCEDURES**

- 3 Limited Warranty
- 4 Warranty Claims
- 5 Exclusions

**6 INTRODUCTION**

- 7 Abbreviation/Definition Table

**13 EQUIPMENT DESCRIPTION**

- 13 Power Take-Off
- 14 Hydraulic Reservoir and Filter
- 14 Hydrostatic Pump
- 15 Hydrostatic Motor
- 15 Asphalt Pump
- 16 Spread/Circulate Relief Valve
- 17 Auxiliary Hydraulic System
- 17 Spray Bar
- 18 Double-Fold Wing Configuration
- 18 Circulation Control
- 19 Bar Movements
- 19 Wing Shear Pins
- 19 Cab Console
- 21 Side Control Panel
- 21 Rear Control Panel
- 21 Computerized Rate Control (CRC) System



- 22 Asphalt Heating System (option)
- 22 Wash Down Facilities
- 22 Spray Bar Flushing System
- 23 Hand Spray System
- 23 Pattern Spray Capability
- 23 Remote Curb side Mirror

## **28 SAFETY PRECAUTIONS**

- 28 Personnel Safety
- 28 General Protection
- 28 Protect yourself:
- 30 Pumping Operations
- 31 Burner Operations
- 32 Clean the Equipment
- 32 Safety Decals and Plates

## **35 GENERAL OPERATION**

- 35 **Operating controls, gages, and indicators:**
- 35 **Nozzle size selection:**
- 35 **Loading asphalt:**
- 35 **Heating asphalt:**
- 36 **Circulating asphalt in the spray bar:**
- 36 Console
  - 38 Bar
  - 39 Spray Valve Switches
  - 40 Valve Selector Dial
  - 40 Display

# 2013

- 41 Side Control Panel
- 42 Rear Control Panel
- 44 Asphalt Valve Locations and Functions
- 45 Valve Locations
- 46 Asphalt Tank Gauge
- 46 Asphalt Temperature Gauge
- 47 Selection of Correct Spray Nozzles
- 48 Spray Nozzle Removal and Installation
- 48 Initial Checkout of the Equipment
- 50 Flushing Tank
- 52 Loading Through Valve A
- 54 Loading Through Optional Valve L
- 55 On Load Thru Spray Bar
- 57 Loading Through Manhole
- 58 OFF Load Thru Valve D
- 60 Through Pump Transfer
- 63 Gravity OFF Load (External Pump Transfer)
- 64 Heating Asphalt
- 65 Tank Circulation While Heating
- 66 Heating with Diesel Fired Burners

## 68 OPERATING INSTRUCTIONS

- 68 Spraying Operations with CRC Computerized Rate Control
- 70 Spraying Operations using the optional Front Suction
- 71 Setting Spread Rate Manually
- 73 Hand Spraying While Circulating Spraybar



- 74 Hand Spraying
- 76 Spray Bar Flushing
- 80 Shutting the Equipment Down

## **82 CONSOLE DISPLAY**

- 82 Start Up
- 83 Home Page
- 86 Settings Page
- 89 Spraybar Setup
- 90 Calibration Page
- 95 Switch Diagnostic Page

## **96 SPRAYING COMPLEX PATTERNS**

- 96 Parking Lot
- 104 T - Intersection
- 107 Recommended Operating Practices

## **109 FIELD MAINTENANCE**

- 109 Flush the Spray Bar
- 109 Clear Spray Bar Clogged with Frozen Asphalt
- 111 Clean Asphalt Intake Strainer
- 111 Clean Bar Screen
- 112 Replace Swing Joint Seal
- 113 Replace Asphalt Pump Seals
- 114 Replace Nozzle Valve Stem Seals
- 115 Adjust Actuators for Spray Nozzle Valves
- 116 Adjust Remote Curbside Mirror
- 117 Lubrication

## 2013

- 117 Preparation for Storage
- 117 Removal of Spray Bar
- 117 Hydraulic System Maintenance
- 119 Cargo Pump Operation
- 121 Equalizer Valve Packing
- 121 K Valve (spread circulate) or “bypass valve”



## EQUIPMENT DESCRIPTION

The Model BC-502/CRC Cab Operated Computer Controlled Liquid Asphalt Distributor is pictured below. The following description of the equipment should be read to familiarize yourself with the operating features and capabilities of the Model BC-502/CRC asphalt distributor.



Description

### Power Take-Off

Hydraulic power is used to drive the asphalt pump and move the spray bar. Primary power for the hydraulic system is derived from a power takeoff (PTO) driven by the truck engine. Either a transmission PTO, Crankshaft, REPTO, or an additional engine may be employed. The transmission PTO consists of a gearbox mounted to the truck transmission, from which a driveline connects to a hydrostatic pump. The PTO gearbox operates only when the truck clutch is engaged. When the clutch is disengaged, the PTO stops, in turn stopping the hydrostatic pump and the asphalt pump.



#### Power Take Off (PTO)

The crankshaft and REPTO are driven directly by the truck crankshaft, allowing the hydrostatic pump and asphalt pump to be operated independently of the truck clutch. The additional engine has the hydraulic pumps direct mounted and is used primarily for applications where the truck PTO is not feasible or the horse power required is in excess of truck engine capabilities. The transmission PTO is engaged by use of a switch on the Cab Console. In general, the PTO can be switched on when the truck arrives at the job site and left on continuously until the shift is finished for the day. All configurations of the PTO can be operated at highway speed.

# 2013

## Hydraulic Reservoir and Filter

Hydraulic fluid for the hydrostatic pump and motor is stored in a 15 gallon tank mounted to the truck frame. The system uses Type 46 Hydraulic Fluid. The tank includes a sight glass that indicates the presence of sufficient fluid to operate the system. The tank has an internal 100 mesh suction screen. A 10 micron return filter is located immediately adjacent to the tank. A pressure gauge mounted on the filter housing serves as an indication of the condition of the filter element. When the element is clean and unobstructed, the gauge will indicate pressure in the range 0 to 24 PSI.



Hydraulic Reservoir and Filter

## Hydrostatic Pump

A heavy duty, variable displacement hydrostatic pump is used to drive the hydrostatic motor that turns the asphalt pump through a 3.5 to 1 planetary gear box. The hydrostatic pump is a sealed, self lubricating unit. It operates in either the forward or reverse direction, at any speed within its operating range. Control of the speed of the pump is determined in one of two ways:



Hydrostatic Pump

- a. CRC control, to whatever pump speed is required by the Computerized Rate Control (CRC) System to produce the asphalt flow rate needed to maintain the selected gallons per square yard (GSY) of asphalt distribution at any truck speed. Automatic control occurs only when the selector on the cab Console is in the CRC position.
- b. Manual control, in which pump speed is determined by pre-setting the manual pump speed on the second page of the display or using the GSY switch on the Console. Manual control is possible only when the selector is



in the MANUAL position. The pump control functions are described further in Cab Console Controls. The hydrostatic pump receives power directly from the PTO.

**CAUTION:** *INSUFFICIENT HYDRAULIC FLUID FLOW TO THE HYDROSTATIC PUMP INDICATES A CLOGGED FILTER OR A BLOCKED HYDRAULIC LINE. THIS CONDITION CAUSES THE PUMP TO OPERATE NOISELY. TO AVOID DAMAGE TO THE PUMP, DO NOT OPERATE UNDER NOISY CONDITIONS.*

It is a quiet, smooth running unit under the conditions normally encountered in asphalt spreading operations. Should the pump become noisy, the most common cause is insufficient hydraulic fluid due to a clogged filter or blocked hydraulic line. The pump should never be operated under these conditions.

## Hydrostatic Motor

The Hydrostatic Motor is a fixed displacement type that is driven by the hydrostatic pump through high-pressure hydraulic lines. The motor responds instantaneously to changes in either the speed or direction of the pump. The system is equipped with an integral relief valve that opens if the maximum rated output torque is exceeded, as may occur if the asphalt is frozen or the asphalt pump attempts to force asphalt against a closed valve. The maximum rated torque is engineered to create a maximum asphalt system pressure capability of 70 PSI. The output shaft of the hydrostatic motor is coupled directly to the asphalt pump. A hall-effect sensor installed at the motor shaft coupling provides signal information to the CRC system.



Hydrostatic Motor

## Asphalt Pump

The Asphalt Pump is a positive displacement geared pump. The standard pump has a delivery capacity of 400 gallons per minute (GPM), BC-450 (4" x 400 GPM). The intake and outlet ports are of 4 inch (102 mm) diameter. Optional pumps are BC-300 (3" x 250 GPM), BC-600 (5" x

## 2013

500 GPM), and the BC-960 (8" x 750 GPM). The direct coupling of the asphalt pump to the shaft of the hydrostatic motor through a 3.5 to 1 gearbox results in a direct relationship between truck speed and computer controlled pump output. If truck speed is increased, pump output automatically increases an appropriate amount to maintain the correct flow of asphalt through the spray nozzles. The asphalt pump operates in either direction, at any flow rate within its operating range, as determined by either the Computerized Rate Control (CRC) system or the manual pump controls, see Cab Console Controls. The asphalt flow rates, or pump output, is displayed in GPM on the digital CRC display in the cab of the truck.



**Asphalt Pump**



**Spread/Circulate Relief Valve**

### Spread/Circulate Relief Valve

The asphalt distributor is equipped with a Spread/Circulate Relief Valve that is controlled in tandem with the spray bar MASTER switch. The flow rate is controlled by the CRC system, so that the selected spread rate is always maintained even though the operator increases or decreases the number of open spray nozzles or the travel speed of the asphalt distributor. The pump is capable of pumping any bituminous material at temperatures

up to 400°F (204°C). The pump is easily accessible at the rear of the truck. The standard pump is equipped with a conventional stuffing box or packed seal. An optional version is available with a Teflon lip seal that eliminates the need for periodic re-packing of the stuffing box or packing. An intake screen is provided to protect the pump impellers and chamber from foreign matter in the asphalt. A second screen is used to keep particles from the spray valves and nozzles. With exception of the BC-960, the asphalt pump is equipped with a pressure relief valve



that opens if internal pressure exceeds 70 PSI. The pump is relieved in both directions. An additional safety is provided by the by the hydrostatic transmission, which is designed to hydraulically relieve at 150 PSI asphalt system pressure.

---

**WARNING:** Extreme care must be used during pumping operations to make sure system components operate at their rated pressures. Failure to check the condition of all hoses and connections when pumping, could result in severe burns, injury or death from pumping errors made with faulty components.

---

*Always check conditions of hoses and connections when pumping.*

## Auxiliary Hydraulic System

The Auxiliary Hydraulic system consists of a small hydraulic pump mounted on the main hydrostatic pump, 4 to 8 electrohydraulic valves for control of spray bar movements, and a nonadjustable pressure relief valve. The auxiliary system draws hydraulic fluid from the 15 gallon reservoir mounted to the truck frame. The auxiliary pump provides power for spray bar movements (side shifts right and left, raise, and lower) and wings raise and lower.



Auxillary Hydraulic Pump

## Spray Bar

The spray bar used on the Model BC-502/ CRC distributor is a full circulation type; that is, it permits circulation of asphalt throughout the entire interior of the bar structure. This configuration allows the fully enclosed spray valve bodies to be totally immersed in asphalt, assuring immediate application of material when the valve is opened (instant open/close). The poppet valves that release the spray are opened and closed by electrically controlled air cylinders that operate through a mechanical linkage when the operator actuates the corresponding switches on the Cab Console. Optional “tri-valve manifolds” directly couple individual air cylinders to each



Spray Bar Air Cylinders

poppet, eliminating linkage.

## Double-Fold Wing Configuration

The spray bar can be provided with single fold, double-fold, or triple fold wings, permitting maximum coverage as wide as 24 feet. A double fold wing configuration is pictured left. The outermost segment of a multi fold wing is the first to respond when the switches that control wing movement are actuated. Spray valves are spaced along the bar on 4 inch (102-mm) centers. Valves are controlled in groups of three per switch, occupying 12 inches or 305 mm.

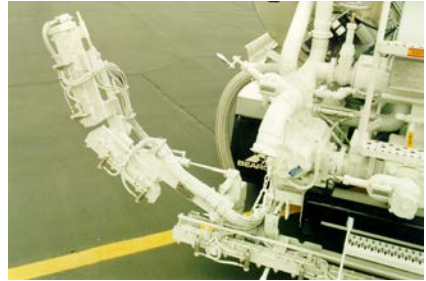

Double-Fold Wing Configuration

## Circulation Control

The spray bar contains two pressure-equalizing valves, one located at each end of the main bar just inboard of the wing swing joint. A third equalizer valve is located in the transverse pipe connecting the two spray bar flexible feed lines. All three equalizer valves are connected to the spray bar MASTER switch on the Cab Panel. When the spray bar master switch is on, the equalizer valves are open, permitting asphalt to flow equally throughout the bar and wings for uniform distribution. When the spray bar master switch is off, the valves are closed. Asphalt then circulates out of the tank, through the pump, through the entire spray bar, and back to the tank.

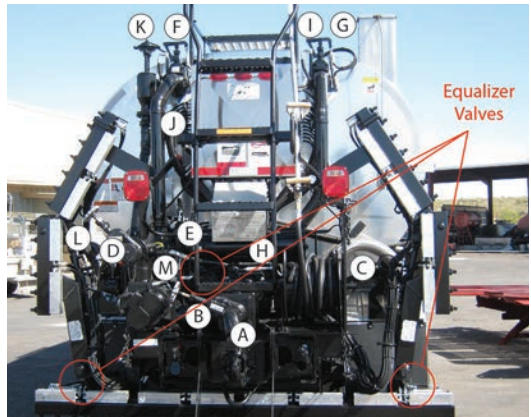

Equalizer Valve Locations



## Bar Movements

The spray bar can be moved right and left to a maximum of 13 inches (33 cm) in either direction, allowing a total horizontal travel of 26 inches (66 cm). The bar can be raised to approximately 20 inches above the ground and lowered to within 10 inches of the ground (51 and 15 cm respectively). A hydraulic lockout valve holds the bar at any height within this range. A mechanically adjustable stop is provided to limit downward travel to a set position. The right and left wings can be hydraulically lifted 90° to a vertical position, which places them well within the width of the truck. All bar movements are powered by hydraulic cylinders and controlled by switches on the Cab Console and Rear Control Panel. When in the horizontal position, the wings can pivot forward or backward without damage if they should hit an obstruction..



Bar Break-Away

## Wing Shear Pins

Replaceable shear pins are used to assure correct alignment of the wings with the main bar. Spare shear pins are provided with Model BC-502 /CRC (use only soft cotter pins).

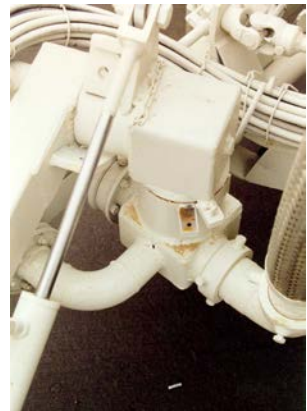

Wing Shear Pins

## Cab Console

The operation of the Model BC-502 /CRC distributor can be controlled from the driver's seat of the truck through the Cab Console. The following functions are controlled with switches on the panel:

- a. Power on,
- b. Open and close spray valves,
- c. Open and close right and left marker valves,
- d. Position spray bar (raise, lower, side shift),

## 2013

- e. Raise and lower wings,
- f. Engage PTO,
- g. Adjust remote curb side mirror,
- h. Control pump direction,
- i. Adjust spread rate,
- j. Beacon Light,
- k. Bar and Wing Latch,
- l. Taper Cut Nozzle Cut Control,
- m. Valve Selector Switch,
- n. Computerized Rate Control (CRC) and Manual with system monitor.

A *master* switch is provided for the purpose of simultaneously opening or closing all spray valves for which the individual switches are in the *on* position. The functions of the Cab Console are further described in GENERAL OPERATION.



Cab Console



## Side Control Panel

The Side Control Panel is equipped with a Valve Selector Switch and provisions for controlling the speed and direction of the asphalt pump when the Cab Console Selector Switch is set to “Load Outside”. The operator selects pump and spray options with the rotary selector switch that indicates an option and the necessary pneumatically operated remote control valves to actuate. The functions of the Rear Control Panel are further described in, GENERAL OPERATION.



Side Control Panel

Description

## Rear Control Panel

The Rear Control Panel is equipped with switches for positioning the spray bar, raising and lowering the wings, and lighting the retort or asphalt heating burners. The functions of the Rear Control Panel are further described in General Operation.



Rear Control Panel

## Computerized Rate Control (CRC) System

The BearCat Computerized Rate Control System is installed on Model BC-502/CRC distributors as standard equipment.

The CRC System automatically holds the spread rate at the selected application regardless of truck speed or gearing, in forward or reverse or during mid pass changes in spray bar width. The computer controlled system automatically speeds or slows the asphalt pump as needed to compensate for variations in vehicle speed, spray bar width or rate adjustment. The operation of the CRC System is described in

## 2013

### GENERAL OPERATION.

#### Asphalt Heating System (option)

This option provides one or two 8 inch diameter flues, each containing an atomizing diesel oil burner, or a propane burner. Solid-state igniters powered from the vehicle electrical system individually ignite the burners. Switches located on the Rear Control Panel control the igniters. The burner(s) will operate only when the truck parking brake is engaged for obvious safety reasons. Asphalt temperature is displayed on a dial thermometer mounted at the rear of the asphalt tank.



Diesel Burner

#### Wash Down Facilities

The standard wash down system installed on the Model BC-502/CRC distributor consists of an 8-gallon truck air pressurized reservoir that propels a biodegradable solvent to the wash down spray hose. The wash down hose is 25 feet (7.6 m) long and is fitted with an on off valve.



Flush and Washdown Tank

#### Spray Bar Flushing System

An on board 25 gallon solvent reservoir that is heated by the truck engine coolant system to circulate through the spray bar for the purpose of flushing it clear of residual asphalt. The 25 gallon reservoir may vary in size based on tank length.



## Hand Spray System

The Model BC-502/CRC distributor is equipped with a hand spray consisting of an aluminum spray wand and 50 feet (15 m) of rubber hose. The spray wand is fitted with a drip free valve. The hose is stored on a manually operated reel with a swivel.

## Pattern Spray Capability

As described previously, the spray valves in the standard BearCat spray bar can be opened and closed in groups of 3 valves per control panel switch. This design enables the operator to exercise a high degree of control in the application of liquid asphalt material. Patterns can be deposited in increments as small as 1 foot or as large as the combined width of the main bar and the wings. In combination with the ability of the bar to shift laterally approximately 13 inches



Hand Wand and Hose Reel

in either direction, this selectivity allows the user to apply asphalt to precisely defined areas in relatively complex patterns.

## Remote Curb side Mirror

The remote curb side mirror can be positioned from the driver's seat to show the normal field of view for highway travel, or adjusted to view the curb side wing extension and the space adjacent to the truck. The mirror position is controlled through switches on the Cab Console. The mirror movements are powered by compressed air taken from the truck supply.

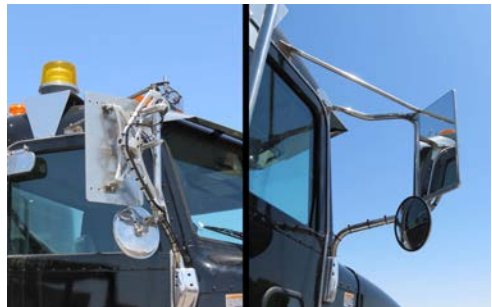

Remote Mirror

# 2013 Specifications

## Meters and Gages

(CRC System Operating)..... +/-1.0% accuracy\*  
Asphalt Tank Gauge .....50 Gallon Increments

## Maximum Temperature Capability

Asphalt Temperature ..... Pencil/Dial Thermometer  
Standard Rubber Feed Hose ..... Intermittently 350°F (177°C)  
Optional Stainless Steel Feed Hose ..... 450°F (232°C)

## Asphalt Handling Functions:

Load through spray bar, Off-load, Transfer, Circulate, Heat, Spray, Flush.

## BearCat Asphalt Pump

Type .....Positive Displacement  
Internal Pressure Relief ..... 70 PSI  
Standard Capacity ..... 400 Gallons Per Minute

## Spray Bar Seals

Standard ..... High Temperature Shaft Packing  
Optional ..... Teflon Shaft Seal  
Wing Swivel Seals ..... Lip Seal

## Over-all Length:

Standard ..... 12ft (3.7m)  
Options ..... Up to 24ft (7.3m)

## Pump Drive

Type ..... Hydrostatic Transmission  
Axial Piston Variable Pump ..... 4.57ci(75cc)/revolutions  
Axial Piston Fixed Motor ..... 1.52ci(25cc)/revolutions



Position Control:

Maximum Height .....	20in (51cm)
Minimum Height .....	10in (15cm)
Total Side Shift .....	26in (66cm)
Wing Lift .....	90°

Spray Control Increments:

Standard .....	1ft (30cm)
Control.....	Console Switches

Spray Nozzle Valves

Type.....	Poppet
Center-to-Center Spacing .....	4in (10cm)
Actuation .....	Solenoid/Pneumatic Cylinder

Line Markers

Number .....	2 (Right & Left)
Actuation .....	Solenoid/Pneumatic Cylinder

Asphalt Piping

Standard Intake Diameter .....	4in (10cm)
Discharge Diameter.....	3in (8cm)

Asphalt Valves

Type .....	Gate/Butterfly
Control.....	Console Switches
Actuation .....	Solenoid/Pneumatic Cylinder /Manual

Flexible Hoses (feed to spray bar)

Diameter.....	2.5in (6.4cm)
Standard (250°F).....	Rubber
Optional (450°F) .....	Stainless Steel

### Data Displays

Gallons per Square Yard  
Feet per Minute  
Gallons per Minute  
Spray Bar Width  
Distance Traveled  
Nozzle Size  
Gallons Used

### Asphalt Screens

Load Screen ..... 1/4in (6.4mm) mesh  
Spraybar Screen..... 3/32in (2.4mm) mesh  
Construction ..... Cylindrical

### External Wash-down/Flush

Tank ..... 8 Gallons Pressurized  
Withdrawal ..... Truck Compressed Air  
Tank Capacity..... 15 Gallons (57 L) or as Specified  
Hose Diameter..... 1/4in (6.4mm)  
Hose Length..... 25ft (7.6m)

### Asphalt Tank (as specified)

Capacity ..... 1000-4800 Gallons (3785-18,169L)  
Shell Standard ..... 10 Gauge HSLA  
Shell Optional ..... 12 Gauge HSLA  
Heads Standard ..... 3/16 Plate HSLA  
Heads Optional ..... 10 Gauge HSLA  
Insulation Material..... Mineral Wool  
Insulation Thickness..... 2in (5cm)  
Manhole Diameter ..... 20in (51cm)  
Internal Crawl Holes ..... 20in (51cm)  
Jacket ..... 040 Aluminum  
Vent ..... 2in (5cm)  
Overflow Drain ..... 3in (7.6cm)  
Mounting ..... Single Blade Bolster; Resilient Attachment to Truck  
Grip-Strut Catwalk ..... 22in (51cm)



### Curb side Remote Mirror

Size .....	9in Wide X 16in High (23cm X 41cm)
Movements .....	Up & Down, In & Out
Control.....	Console Switches
Actuation .....	Pneumatic (truck air supply)

## ASPHALT HEATING SYSTEM OPTION

### Diesel Fired Burner

Air Blower.....	12V Electrically driven includes
Fuel Pump .....	integral fuel pump and fuel filters.
Fuel Source.....	Truck Tank
Burner Flue Liner .....	Stainless Steel
Exhaust Flue .....	Stainless Steel-rain cap provided
Heating Capacity, BTU .....	Up to 770,000 per flue

#### Notes:

\* (CRC System Operating) – Specifications indicates spread rate accuracy obtainable when equipment is properly maintained and operated in accordance with the instructions in this manual.

## SAFETY PRECAUTIONS

### Personnel Safety

*The safety of personnel working with or near the BC-502 depends on careful observance of the precautions and protective measures in this section.*

---

**WARNING:** THE MATERIALS USED IN THE BC-502 ARE NORMALLY HEATED TO 300° F TO 400° F DURING APPLICATION. MATERIALS USED AT THESE TEMPERATURES CAN CAUSE SERIOUS OR FATAL BURNS AND CAN BECOME EXPLOSIVE UNDER CERTAIN CONDITIONS. DIESEL FUEL USED IN THE BURNERS WHICH HEAT THESE MATERIALS IS HIGHLY FLAMMABLE. EXTREME CARE MUST BE EXERCISED AT ALL TIMES TO ASSURE THE SAFETY OF PERSONNEL WORKING IN PROXIMITY TO THESE POTENTIALLY HAZARDOUS CONDITIONS.

---

*Read each safety rule and make them a part of the daily work routine.*

### General Protection

---

**WARNING:** EXHAUST SPARKS FROM AN ENGINE CAN IGNITE VOLATILE GASES. ALWAYS KEEP A DRY CHEMICAL FIRE EXTINGUISHER FULLY CHARGED AND ON HAND AT ALL TIMES.

---

### Protect yourself:

*Always wear suitable gloves and protective clothing (long sleeve shirt and long pants) when touching any part of the equipment.*

*ALWAYS keep your body and clothing well clear of rotating drive parts.*

---

**WARNING:** EXTREME CARE MUST BE USED WHEN CHANGING AN ASPHALT DISTRIBUTOR FROM WET ASPHALT TO HOT ASPHALT. FAILURE TO FOLLOW THE PROPER PROCEDURES COULD CREATE A POTENTIAL STEAM



**EXPLOSION HAZARD, RESULTING IN SEVERE BURNS,  
INJURY OR DEATH.**

---

**WARNING: Potential Explosive/Fire Hazard Conditions**

---

**WARNING: FAILURE TO COMPLY WITH THE FOLLOWING LIST  
OF SAFETY RULES COULD RESULT IN A FIRE OR  
EXPLOSION THAT COULD CAUSE SEVERE BURNS,  
INJURY OR DEATH.**

---

- **DO NOT ALLOW LIGHTED CIGARETTES, OR ANY BURNING MATERIAL NEAR OPEN MANHOLES OR OVERFLOW VENTS.**
- **DO NOT USE GASOLINE IN A BURNER. THE BURNERS OPERATE ON DIESEL FUEL ONLY.**
- **DO NOT HEAT MATERIAL BEYOND THE MAXIMUM TEMPERATURE RECOMMENDED BY THE SUPPLIER.**
- **DO NOT OFF-LOAD MATERIAL WITHIN 20 MINUTES OF HEATING.**
- **DO NOT HEAT MATERIAL IN A TANK THAT LEAKS.**
- **DO NOT LOAD HOT ASPHALT INTO A WET MACHINE WITHOUT PROPER FLUSHING.**

**WARNING:** Worn or faulty hoses can burst and cause severe burns or death. **CHECK CONDITION OF ALL HOSES BEFORE OPERATING.**

---

- *ALWAYS wear a face shield when pumping hot asphalt.*
- *ALWAYS check the condition of the transfer hoses before beginning pumping operations.*
- *ALWAYS check to make sure that all pipe and hose connections are secure before opening a valve.*
- *ALWAYS start the asphalt pump VERY SLOWLY, and make sure that all hoses and valves work properly.*
- *ALWAYS open the manhole cover SLOWLY to relieve pressure in the tank.*
- *If it is necessary to stop the flow of material while filling the tank, close the suction valve or pump intake. NEVER pump against a closed valve.*
- *ALWAYS make sure the fill-line connection is securely attached before opening an intake valve.*



## Burner Operations

---

**WARNING: POTENTIAL FIRE OR EXPLOSION HAZARDS EXIST WHEN OPERATING THE BURNERS. FAILURE TO FOLLOW THE BURN OPERATION SAFETY PROCEDURES COULD RESULT IN SEVERE BURNS, INJURY OR DEATH.**

---

- *ALWAYS use the auto ignition switch or a hand torch to ignite a burner. NEVER use a match or lighter.*
- *ALWAYS make sure flues are covered by at least a 6-inch (152 mm) of material before heating.*
- *Burners should NEVER be operated under the following conditions:*
  1. *During unloading or loading operations.*
  2. *While the vehicle is unattended.*
  3. *While the vehicle is in motion.*
  4. *When the vehicle is parked in a confined area.*
  5. *When the content of the tank is unknown.*
- *NEVER remove materials from the tank while the burners are operating, or the automatic burner controls are set to operate.*
- *NEVER remove materials to the point of uncovering flues from the tank within 20 minutes after heating.*

### *When using dual burners:*

- *ALWAYS ignite the inside burner (lower burner) first.*
- *In the event it becomes necessary to re-ignite the inside burner, NEVER reach across a lit burner to re-ignite an inside burner.*
- *ALWAYS allow the flues to ventilate for a least two (2) minutes before re-igniting a burner that has gone out.*
- *ALWAYS allow sufficient space in the tank for the material to expand when heating.*
- *ALWAYS keep material that contains volatile cutbacks (solvents) away from open flames or sources of sparks during spray operations.*

## 2013

- *ALWAYS make sure to keep a hand spray wand pointed AWAY from personnel.*
- *NEVER spray off material below the fire line within 20 minutes of heat operation.*

### Clean the Equipment

*Keep the unit clean. A dirty unit cannot be monitored for safety as well as a clean unit.*

- *ALWAYS check the following components for wear or defects after the first week of operation, and monthly thereafter:*
  1. *Tank-mounting tie-downs*
  2. *Fasteners*
  3. *King plate fasteners (if used)*
  4. *Suspension components*
  5. *Running gear components.*

### Safety Decals and Plates

*All safety decals and plates must be clean, legible and in good condition.*

- *Always clean any safety decal or plate that becomes dirty.*
- *Always check the condition of safety decals and plates before each use.*
- *Always replace any safety decal that is illegible through wear and tear or is peeling off the equipment.*
- *Never operate the equipment with a safety decal or plate that is hard to read or is missing.*
- *The following safety decals are available from BearCat Mfg.*



**WARNING**

Do not light burners unless flues are covered. Explosion can occur causing death or serious injury.

Do not operate burners with less than:

Lower Burner \_\_\_\_\_ Gal.  
Lit. \_\_\_\_\_ Gal.

Upper Burner \_\_\_\_\_ Gal.  
Lit. \_\_\_\_\_ Gal.

**9 DCL-21203**

**PUMPING HOT MATERIAL (COVER 200° F) INTO A TANK OR SPRAYING SYSTEM THAT CONTAINS WATER (EMULSIFIED ASPHALT IS 40% WATER) CAN CAUSE A DISASTROUS STEAM EXPLOSION THAT WILL CREATE THE BIGGEST MESS YOU HAVE EVER SEEN AS WELL AS SEVERELY BURNING OR KILLING ANYONE IN THE AREA.**

IF THERE IS **ANY** MOISTURE IN THE TANK, SPRAY BAR, OR CIRCULATING SYSTEM, ALLOW A SMALL PORTION OF HOT MATERIAL TO CIRCULATE THROUGH ALL SYSTEMS BEFORE FILLING THE TANK.

**DANGER**

**8 DCL-21204**

**WARNING**

Do not change asphalt grades without reading operators manual. Explosion can occur causing death or serious injury.

**23 DCL-21208**

**WARNING**

Fill line cap or connection should be securely attached before operating intake or suction valve. Loose connections can cause burns from hot asphalt.

**18 DCL-21211**

**WARNING**

Eruption or explosion could cause serious injury or death.

1. Open manhole slowly to relieve pressure that may exist in tank.
2. Lit cigarettes or other sources of combustion should remain clear of open manholes or overflow vents.
3. Periodically check and clean 3" overflow tube.

**2 DCL-21207**

**WARNING**

Do not exceed the vehicle **GVWR** or **GAWR**. Nominal tank capacity is based on 7.7 lbs./gal. Load volume must be reduced when carrying heavier products. If you exceed the **GVWR** or **GAWR** you could lose control, resulting in **severe injury or death**.

**29 DCL-21212**

**WARNING**

**HOT MATERIAL HAZARD**

Hot Material and Machine can cause serious burns. To prevent serious injury or death:

1. Do not touch material or machine with bare skin. Contact can cause serious burns.
2. when operating.
3. Review safety and operating instructions before starting.

**25 DCL-21201**

**WARNING**

**HOT MATERIAL HAZARD**

To prevent serious injury or death:

1. Stay away from burner and flue stack when heating material in tank.
2. Keep others away.
3. Follow burner operating instructions.

**16 DCL-21202**

**DANGER**

**EXPLOSION HAZARD**

To prevent serious injury or death:

1. keep machine and material away from sparks or open flames. Fumes are flammable.
2. Do not load when water is in bottom of tank. Steam can cause explosion.
3. purge liquid from spray bar before circulating asphalt through pumps or booms. Vapors can explode.
4. Do not operate burners unless burner tubes are completely submerged.
5. Do not mix grades of material.
6. Do not exceed asphalt flash point temperature. Hot fumes can explode.
7. Do not operate burners while vehicle is being loaded or is in transit.

**21 DCL-21205**

**DIRECTION FOR LIQUID PETROLEUM BURNERS**

1. OPEN STACK COVER.
2. SET CONTROLS FOR CIRCULATE IN TANK.
3. SUSPEND THERMOMETER FROM MANHOLE IF MATERIAL DOES NOT COVER THERMOMETER WELL.
4. READ DETAILED INSTRUCTIONS IN MANUAL.
5. USE LIQUID WITHDRAWAL SYSTEM ONLY.
6. CLOSE VALVES AT BURNER.
7. OPEN SUPPLY VALVE SLOWLY. CHECK LEAKS.
8. CIRCULATE MATERIAL; APPROX. 150 G.P.M.
9. LIGHT PILOT WITH BURNER LIGHTER.
10. OPEN BURNER VALVE
11. SET FUEL PRESSURE AT 40 P.S.I.
12. WHEN SHUTTING DOWN, ALWAYS CLOSE SUPPLY VALVE FIRST.
13. AFTER SHUTTING DOWN BURNERS, CLOSE STACK COVERS TO PREVENT HEAT LOSS.

**20A MSM-80038**

Safety

**WARNING SAFETY HAZARDS**

1. Periodically check all body mounting tie downs and fasteners.
2. Use insulated gloves and face shield when handling spray bar sections of hoses.
3. All pipe and hose connections must be secure before operating valves.
4. Keep area clear of open flame or sparks when spraying material.
5. Do not stand in a location such that accidental opening or spray bar valves will cause contact with the spray.
6. If moisture is present in tank, do not load with material having a temperature over 100° F. When filling unit in which moisture may be present in the spray, use or circulating air, draw a small portion of hot material to circulate in bar before filling tank.
7. When handspraying, maintain gun in proper position and watch for other operators.
8. Remain clear of rotating drives when unit is in operation.
9. Sparks from engine exhaust can be a source of ignition to volatile gases.
10. KEEP UNIT CLEAN FOR SAFETY AND OPERATION.

23 MSM-80042

**CAUTION**

1. Read and understand Operator's manual before using.
2. Train operators before allowing them to use machine. An untrained operator is not qualified to use machine.
3. Wear protective gear for face, hands, feet and body when operating machine.
4. Keep all grounds in place.
5. Keep a fire extinguisher in cab.
6. Asphalt and machine are hot and can cause severe burns.
7. Do not operate burners when filling or transporting or when burner tubes are not completely submerged.
8. Do not load when there is water in bottom of the tank.
9. Purge spray bar of fluid before circulating hot material to prevent meltdown.
10. Do not heat tank above material flash point.
11. Clear area of bystanders before starting.
12. Close pressure tank valves and then burner valve when circulating burner.
13. Keep machine and material away from sparks and open flame.
14. Do not drink and drive.
15. Review safety instructions before starting.

22 DCL-21210

**WARNING BURNER OPERATION**

1. Always have dry chemical type fire extinguisher available and in good condition.
2. When heating material, position unit broadside to wind possible.
3. Use fuel oil only (not gasoline) for burners.
4. Do not operate burners unattended or while vehicle is in transit or in confined area.
5. Allow sufficient space in tank for expansion of material when heating.
6. Cover flues at least 4" before heating material.
7. Avoid heating material in leaking tank.
8. Use torch (not match or lighter) to ignite burner.
9. When burners go out, allow flues to ventilate before reigniting.
10. Do not heat material beyond manufacturers recommended temperature.

20 MSM-80043

**DANGER STOP**

**NEVER GET UNDER THIS TRUCK IF THE ENGINE IS RUNNING!**

**NUNCA SE META DEBAJO DEL CAMIÓN CUANDO EL MOTOR ESTÉ EN MARCHA!**

32 DCL-21213 (3 IN KIT)

**CAUTION**

**HOT SURFACE REMAIN CLEAR UNTIL COOL.**

5 MSM-80039

**CAUTION**

**ALWAYS HAVE SHIELDS IN PLACE & REMAIN CLEAR OF MOVING PARTS.**

15 DCL-21209

**WATCH YOUR STEP**

11 DCL-51729

**CAUTION**

**HOT ASPHALT DISCHARGE 450° F!**

19 MSM-50078

**-CAUTION- REMOVE HOSE BEFORE CLIMBING LADDER.**

10 DCL-21490

**WARNING**

**THIS BURNER EQUIPMENT MUST NOT BE OPERATED WHILE THE VEHICLE IS BEING LOADED OR IS IN TRANSIT, OR WHEN THE BURNER TUBES ARE NOT COMPLETELY SUBMERGED**

17 DCL-26163

**FLUSH DIESEL FUEL ONLY REFER TO FLUSHING INSTRUCTION**

4 DCL-21478

**BIODEGRADABLE SOLVENTS OR OIL ONLY NO PETROLEUM DISTILLATES**

**CAUTION**

**CRACK CAP & BLEED AIR BEFORE REMOVING**

3 DCL-21479



## GENERAL OPERATION

---

**WARNING:** BEARCAT EQUIPMENT USES VOLATILE MATERIALS AT HIGH TEMPERATURES AND PRESSURES. THIS EQUIPMENT EMPLOYS HIGHLY COMBUSTIBLE OR EXPLOSIVE FUELS. POTENTIALLY LIFE-THREATENING HAZARDS MAY EXIST DURING EQUIPMENT OPERATION. ONLY QUALIFIED PERSONNEL SHOULD ATTEMPT TO OPERATE, SERVICE OR MAKE ADJUSTMENTS TO THE BEARCAT EQUIPMENT.

---

**WARNING:** TO AVOID POTENTIAL SEVERE BURNS, INJURY OR DEATH, PERSONNEL MUST READ SECTION 2 (SAFETY PRECAUTIONS), BEFORE OPERATING BEARCAT EQUIPMENT.

---

**NOTE:** BearCat Manufacturing assumes no liability for accident or injury incurred through improper use of this equipment.

This Section contains information with which the operator must be familiar in order to prepare the Model BC-502/CRC distributor for spraying operations. Five essential areas are covered:

### Operating controls, gages, and indicators:

- The operator should thoroughly understand the functions of all controls before attempting to use the equipment.
- Operation of the Computerized Rate Control (CRC) System.

### Nozzle size selection:

- The basis for the choice of a spray nozzle is given and nozzle installation procedures are outlined.

### Loading asphalt:

- Three alternate methods are described, the choice depending on the circumstances.

### Heating asphalt:

- Procedures are given and warning and cautionary notes are emphasized for heating material to the required temperature.

# 2013

## Circulating asphalt in the spray bar:

- The procedure is given for circulation prior to spraying.

Familiarity with these eleven areas of activity will prepare the operator for efficient, safe operation of the equipment.

*To understand how the equipment at the rear of the BearCat equipment works, the operator should first operate the rear control panel functions before operating from the front control panel.*

## Console

### GSY (switch)

Inc/Dec Rate Selector raises or lowers the **GSY** or the **IDLE**.

### PTO

Operates the air shift to the truck transmission. Depress the truck clutch before turning **on**.

This switch must be re-cycled each time the “Power” switch is turned **on**.





### Heat

Operates electric heat option. Does not operate diesel or propane fired retort.

### Pump

Controls the asphalt pump rotation direction. Understand the pump rotation functions before cycling this switch.

This switch must be recycled each time the “Power” switch is turned on.

### Manual

Select Manual pump speed control or **CRC** (computerized rate control).

### Bar Latch

Optional hydraulic bar latch for travel.

### Beacon

Controls beacon light.

### Tank

Optional remote tank valve control option for rear or front suction.

When “Spread Heat” or “Circulate Heat” is selected with the Selector Switch, Front opens valve “G” and Rear opens valve “C”.

### Power

Main power switch for total BearCat Machine – nothing at the rear works until this switch is on. If it has been turned off and then back on, certain functions (Master, Pump, and PTO) will have to be re-set.

### Error

Indicator light for possible malfunction or operation of equipment beyond capabilities.

**NOTE:** To understand how the equipment at the rear of the BearCat equipment works, the operator should first operate the rear control panel functions before operating from the front cab console.

### Left Wing Un-Lock

Left button on top of the Console, Unlocks the left inner wing so it can be lowered. Inner wings automatically lock in the full upright position.

# 2013

## Right Wing Un-Lock

Right button on top of the Console, Unlocks the right inner wing so it can be lowered. Inner wings automatically lock in the full upright position.

## L. Wing & R. Wing

**#1:** This raises and lowers the wing section next to the main spray bar.

**#2:** On a Double Fold, raises and lowers the 2<sup>nd</sup> wing section out from the main spray bar.

**#3:** On a Triple Fold, raises and lowers the 3<sup>rd</sup> wing section out from the main spray bar.

NOTE: On the top of the Cab Console are two momentary buttons to unlatch the #1 wing on each side.

## Mirror

Up and down positions the right mirror up for travel and down for spraying.

In and out moves the right mirror left and right for better visibility.

---

**WARNING:** Make sure all personnel are clear of the rear area of the truck when the wings or the spray bar are moved. Failure to keep a safe distance could result in severe injury or death.

---

## Bar

### Raise & Lower

Control of spray bar height.

### Left & Right

Side shifting of spray bar.

---

**WARNING:** If the master switch and any section switch is turned on when lowering a wing, the wing will turn on (spray). This could result in severe burn, injury or death to personnel close to the wing area.

---



## Spray Valve Switches

### Left Wing

Dedicated spray valve control sections on left wing. (One switch per section)

### Main Bar

Dedicated spray valve control sections on main 8ft center spray bar. (One switch per section)

### Right Wing

Dedicated spray valve control sections on right wing. (One switch per section)

NOTE: The standard “section” or “cut” is 3 nozzles (1 foot). Optional 2 foot sections or cuts have been produced controlling 6 nozzles.

### L. Marker & R. Marker

MAST – turns on single spray nozzle at extreme end of spray bar with the spray bar “Master” switch. ON – (Momentary) turns on single spray nozzle at extreme end of spray bar independent of “Master” switch.

### Master

This switch turns on or off any sections of the main bar and left and right wings, that have been selected with both the dedicated spray valve controls and the Taper Cut.

### Taper Cut

Two switches incrementally cut-off or turn-on spray bar nozzles each time the switch is pressed. The left switch starts at left end of left wing and cuts in and back out. The right switch starts at right end of right wing and cuts in and back out. You can start cutting from one side all the way across the spray bar to the opposite end, but you must turn them back on with the same switch. Nozzles can be selected by Taper Cut switches or dedicated bar switches with Master on or off. Both Taper Cut selection and dedicated bar switch must be on to operate nozzle.

# 2013

## Valve Selector Dial

Controls the asphalt plumbing valves based on selection.

### OFF

All asphalt valves closed and pump stopped.

### Spread Heat

General spreading with spray bar and full circulation. Opens valves “C, E, and K” and enables pump.

### Load Outside

Disables Cab Console and enables Side Control Panel for loading and off-loading.

### Circulate Heat

Tank circulation with pump. Opens valves “C and F”, and enables pump.

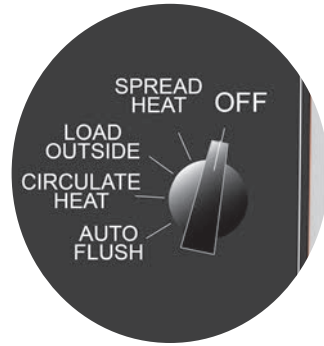

## Display

GSY FPM GPM Width- where GSY = spread rate in gallons per square yard as presently entered into the CRC system; FPM = vehicle speed in feet per minute; GPM = asphalt pump flow rate in gallons per minute; and Width = spray bar width in feet, as determined by the setting of the control panel spray bar switches.



Display



## Side Control Panel

When the Cab Console Selector Switch is set to “Load Outside” the Cab Console is disabled and the Side Control panel is active. The Side control panel is disabled when the Cab Console selector switch is set to anything but “Load Outside”.

### Valve Selector Dial

Selections for loading and off-loading material. The description describes procedure, which valve to connect the load hose, pump direction, and the lettered valves in operation. *When making a selection, the “Pump/Valves” (red button) must be OFF and the “Pump” Neutral.*

### Pump/Valves

Pulling the red button actuates the valves selected by the Valve Selector Dial and enables the pump. Push the red button to stop everything. Pump



Side Control Panel

### Pump direction

When switched Forward, the pump flows in the bottom and out the top. When switched Reverse, the pump flows in the top and out the bottom. In the center position, the pump is stopped.

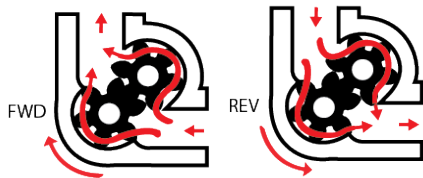

### Manual Increase Speed

Turning the knob clockwise increases the pump speed. *To avoid pump or hose damage, start every manual pumping operation with the speed control at zero (fully ccw) and increase the speed slowly while observing the pump and hoses. Always leave the pump direction control in neutral and manual increase speed at zero or to the left.*

---

**WARNING: EXTREME CARE MUST BE USED DURING PUMPING OPERATIONS TO MAKE SURE THAT SYSTEM COMPONENTS OPERATE AT THEIR RATED PRESSURES. FAILURE TO CHECK THE CONDITION OF ALL HOSES AND CONNECTIONS WHEN PUMPING, COULD RESULT IN SEVERE BURNS, INJURY OR DEATH.**

---

## Rear Control Panel

### Hyd. Bar Lock

Open to unlatch optional hydraulic bar latch. Close to engage or latch.

### Swing

Left & Right Side shifting of spray bar.

### Lift

Raise & Lower.

Control of spray bar height.



Rear Control Panel

### LH & RH Wing Locks

Rubber coated momentary switches for unlocking the wing locks. Wing locks automatically engage when the inner wing is raised completely.

### L. Wing & R. Wing

**#1:** This raises and lowers the wing section next to the main spray bar.

**#2:** This raises and lowers the wing section 2<sup>nd</sup> out from the main spray bar.

**#3:** This raises and lowers the wing section 3<sup>rd</sup> out from the main spray bar.

**NOTE:** On the top of the Rear Control Panel are two rubber coated momentary buttons to unlatch the #1 wing on each side.



---

**WARNING: IF THE MASTER SWITCH AND ANY SECTION SWITCH IS TURNED ON WHEN LOWERING A WING, THE WING WILL TURN ON (SPRAY). THIS COULD RESULT IN INJURY, SEVERE BURN OR DEATH TO PERSONNEL CLOSE TO THE WING AREA.**

---

### R. Burner

(Right or Lower Burner)

On – Runs and ignites burner.

Off – Stops burner.

Cool Down – After burner is stopped, run in cool down for at least five minutes to cool burner liner. *If you fail to cool down the burner, it will melt the pump coupling and the ignition module.*

### L. Burner

This operates the same as the “Right Burner”, but will not operate without the right burner turned on.

- a. Check material in product take covers tubes by 6” or more.
- b. Open exhaust stack lid.
- c. Turn on right or lower burner.
- d. Turn on left or upper burner if necessary or so equipped.
- e. Circulate pump at 150 GPM.
- f. To stop heating, switch burners to cool down position for 5 minutes then to off.
- g. Close exhaust stack lid.

**After heating allow 20 minutes for tube cool down prior to off-loading.**

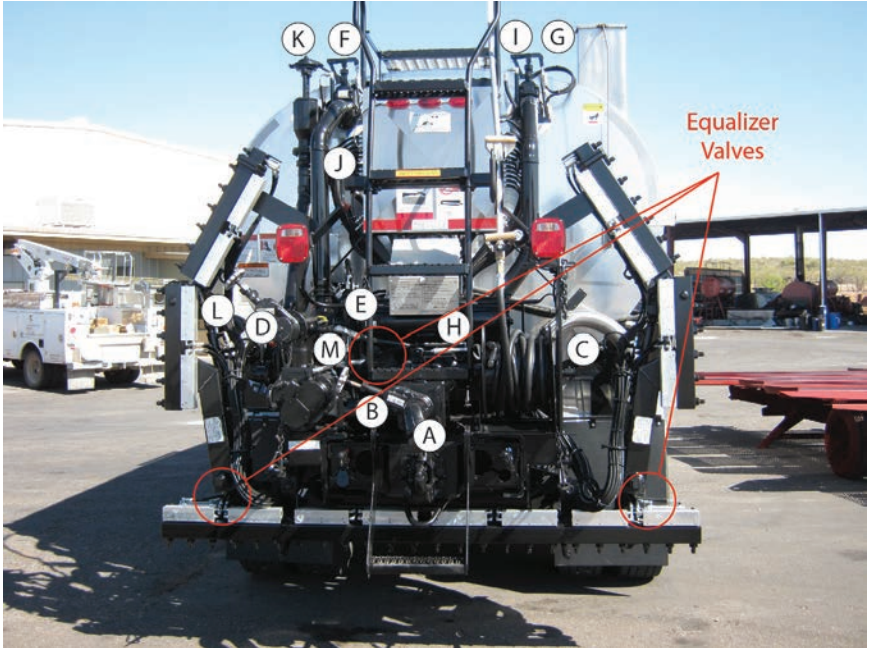

Valve Locations

### Asphalt Valve Locations and Functions

- A. Intake from external source with pump in FORWARD. Gravity un-load.
- B. Pump Isolation (optional).
- C. Main Tank Valve (rear).
- D. External Discharge with pump in FORWARD. Intake from external source with pump in REVERSE.
- E. Spraybar Isolation.
- F. Tank Circulation to front of tank.
- G. Front Suction (optional).
- H. Flush Intake.
- I. Flush Air Vent.
- J. Flush Return.



- K. Spread Circulate (Bypass).
- L. Trough Mounted Side Load (optional).
- M. Hand Wand supply.

### Valve Locations

Study the layout of the valve locations. This plumbing diagram will be used throughout the manual to reference different circulation paths. *All the valves in the circuit are closed.*

Notice the difference between the closed valves and the open valves in the circuit.

### VALVE LOCATIONS (Closed)

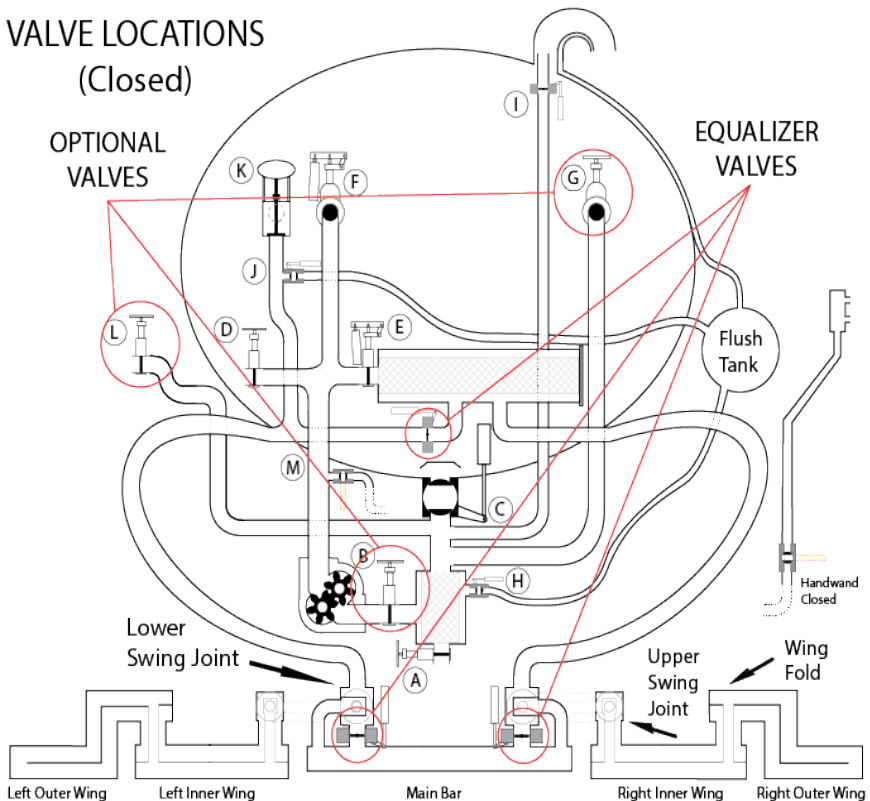

VALVE LOCATIONS  
(Open)

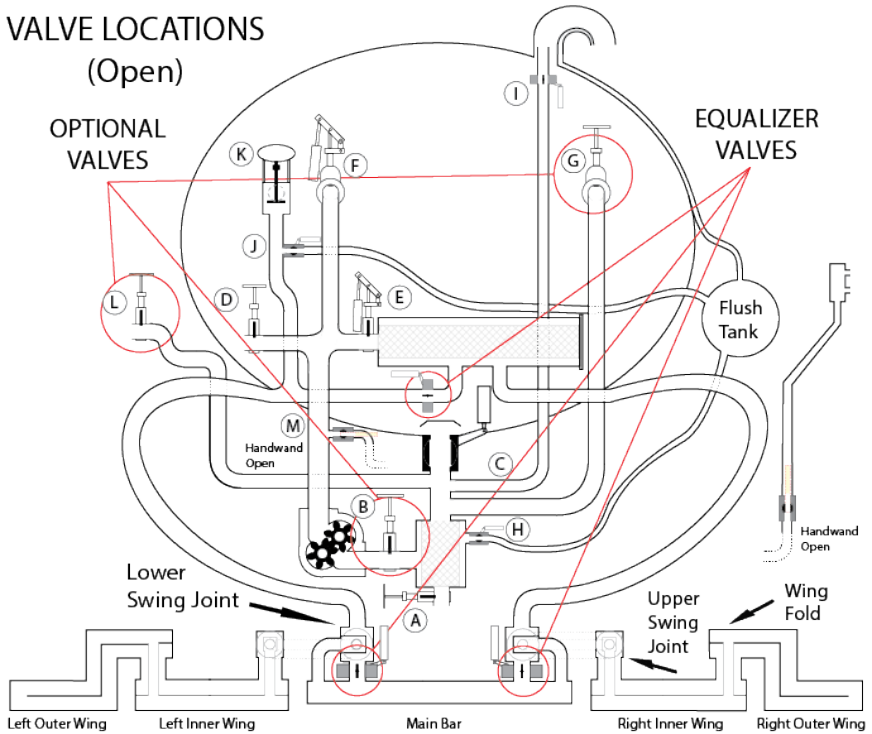

**Asphalt Tank Gauge**

The amount of material in the tank is shown on a flotation gauge mounted on the driver's side of the tank behind the cab. The gauge is marked in 50 gallon increments.

NOTE: The vehicle must be stationary and level to obtain an accurate reading from the asphalt tank gauge.

**Asphalt Temperature Gauge**

The temperature of the material in the asphalt tank is shown on a dial thermometer mounted on the rear of the tank. The thermometer must be monitored closely whenever the burners are operating, as it is essential that material never be heated to a temperature higher than the supplier's recommended maximum.



**WARNING: DO NOT HEAT MATERIAL BEYOND THE MAXIMUM TEMPERATURE RECOMMENDED BY THE SUPPLIER. EXCESSIVELY HEATED MATERIAL COULD CREATE AN EXPLOSION HAZARD, RESULTING IN SEVERE BURNS, INJURY OR DEATH.**

## Selection of Correct Spray Nozzles

When the desired rate of travel in feet per minute and the required spread rate in gallons per square yard are known, the appropriate nozzle size can be selected with the aid of the BearCat Road Oil Spreading Calculator, which is furnished with the Model BC-502 /CRC distributor. If the nozzles presently in the spray bar are not of a suitable size, change them according to the instructions given below. Refer to the side of the Calculator that represents your measurement system (English or metric). On top, in the first window, align the required SPREADING RATE with TRUCK SPEED. Then, in the 3rd window (Spray Bar Pressure), choose the Nozzle that fits most closely in the range of 6 to 12 PSI. The acceptable range is actually 5 to 25 PSI; however, since operation at the lower end is preferable to minimize over-spray and contamination of the equipment, the selected nozzle should be one that will yield the required coverage at 6 to 12 PSI. Additional information that should be derived with the Calculator is the minimum spraying speed for the desired rate with this nozzle. The minimum acceptable spray pressure for creating an acceptable spray fan is 4 PSI. *If the spray bar is turned on at speeds lower than the minimum acceptable travel speed, the spray pattern will be unacceptable.*

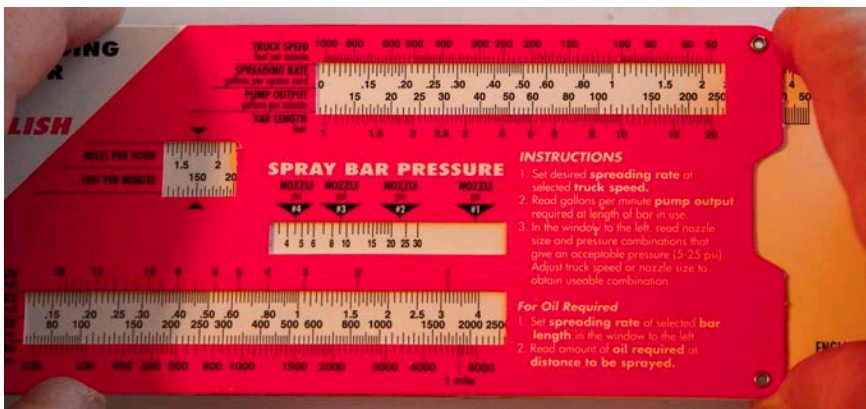

Slide Calculator

## 2013

### Spray Nozzle Removal and Installation

To remove or install nozzles, use the wrench provided with the asphalt distributor. The wrench is equipped with a folding stop that should touch the adjacent nozzle in the spray bar when the nozzle being installed is properly aligned.

The output slot of the nozzle must be at an angle of 30° to the long axis of the spray bar for application of asphalt at the specified rate. **DO NOT** attempt to estimate this angle. **ALWAYS** use the wrench.

*The skill level or reputation of an operator or truck can quickly deteriorate when nozzles are misaligned or poorly maintained and plugged. The skill level of an operator may be overlooked if the truck shoots a beautiful spray pattern.*



Alignment of Spray Nozzle

### Initial Checkout of the Equipment

Each day before loading the tank with asphalt, check the equipment as described below.

#### Check Hydraulic Controls:

- a. Observe the sight glass on the hydraulic reservoir. Some fluid should be visible when the system is cold. If fluid is required, use Type 46 Hydraulic Fluid.



Hydraulic Reservoir and Filter

- b. Start engine, run at idle, Power up Console.
- c. Engage PTO (if equipped).



---

**WARNING:**     **MAKE SURE ALL PERSONNEL ARE CLEAR OF THE REAR AREA OF THE TRUCK WHEN THE WINGS OR THE SPRAY BAR ARE MOVED. FAILURE TO KEEP A SAFE DISTANCE COULD RESULT IN SEVERE INJURY OR DEATH.**

---

- d. Move the *Lift* switch up and down and verify that the spray bar moves accordingly.
- e. With the bar in the lowered position, hold *Swing* switch to the left while watching the spray bar in the mirror. Bar should move approximately 10 inches to the left, and then 10 inches to the right from center.
- f. Return the bar to the center position.

**CAUTION:**     *IF ANY SPRAY BAR VALVE FAILS TO CLOSE DURING THE WING SAFETY SWITCH TEST, NOTIFY A QUALIFIED MAINTENANCE TECHNICIAN. IF A WING VALVE INADVERTENTLY OPENS WHILE IN THE VERTICAL POSITION, A POTENTIAL HAZARD EXISTS FOR SEVERE BURNS.*

Check the operation of the wing safety switches:

- a. With Master Switch OFF and all Spray Valve Control switches OFF, select all spray valves ON with the Taper Cut switches on the display.
- b. Move the *Left Wing* switch up. When the wing elevates to approximately 45°, all spray valves on the wing section should indicate OFF automatically on the display.
- c. Move the *Left Wing* switch down. When the wing lowers to approximately 10°. Above horizontal, the spray valves on the wing section should indicate ON automatically on the display.
- d. Repeat the wing safety switch test for each wing section that can be raised.
- e. Repeat with the *Right Wing* switch while watching the movements of the right wing.

The tank can be loaded by any of the seven methods as described.

---

**WARNING: TO AVOID POTENTIAL SEVERE BURNS, INJURY OR DEATH, PERSONNEL MUST READ SECTION 2 (SAFETY PRECAUTIONS) BEFORE OPERATING BEARCAT EQUIPMENT**

---

**WARNING: EXTREME CARE MUST BE USED WHEN CHANGING AN ASPHALT DISTRIBUTOR FROM WET ASPHALT TO HOT ASPHALT. FAILURE TO FOLLOW THE PROCEDURES COULD CREATE A POTENTIAL STEAM EXPLOSION HAZARD, RESULTING IN SEVERE BURNS, INJURY OR DEATH.**

---

**WARNING: IF ANY MOISTURE IS PRESENT IN THE TANK OR IF THE DISTRIBUTOR WAS PREVIOUSLY USED WITH EMULSIFIED OR WATER BASED MATERIAL, DO NOT LOAD WITH NEW MATERIAL AT ANY TEMPERATURE ABOVE 200°F (93°C). BEFORE MACHINE CAN BE LOADED WITH HOT MATERIAL IT MUST BE FLUSHED USING THE TANK FLUSHING PROCEDURE.**

---

Anytime an asphalt distributor has been used with “emulsified asphalt” or a “water based” product it should be considered “wet”. When changing to hot asphalt (any material over 200°F (94°C) extreme caution must be taken. Emulsified asphalt is approximately 40% water. Water boils at 212°F (100°C) and converts to steam. The water is heavier than asphalt, so it is at the bottom when it converts to steam. This process can take only seconds. When the water converts to steam it displaces the asphalt with enormous force. This will cause the tank to boil over or even erupt splashing hot asphalt on everything within a 100 foot radius.

**NOTE:** *Hot is any material that is in excess of 200°F (94°C).*

The most dangerous situation is to begin circulation of a “wet” spray bar into a full tank of hot asphalt. Spray bar circulation forces the material in the spray bar into the bottom of the tank. If the material is water-based (emulsified asphalt), the hot asphalt in the tank changes the water to instant steam. A gallon of water makes 60 gallons of steam. The steam has tremendous force displacing the asphalt in the tank out the dome lid (if it is not open, the steam pressure will open it) creating



the worst mess you have ever seen as well as severely burning everyone in the area. There are several methods to prevent this, the first and simplest way is to flush the entire system with a Cut-Back asphalt. This method is the safest but does not flush 100% of the water out. This is a good first step to flushing the tank prior to loading hot asphalt. *Shooting emulsion over a long period of time can form “pockets” or areas where wet emulsion is trapped under broken or dried emulsion. Cut-Back may not be hot enough to soften and dissolve these pockets.*

Whenever you use the Asphalt Pump, visualize the flow of material through the pump as follows:

Pump in forward – Material flows in at the bottom out at the top.

Pump in reverse – Material flows in at the top out at the bottom.

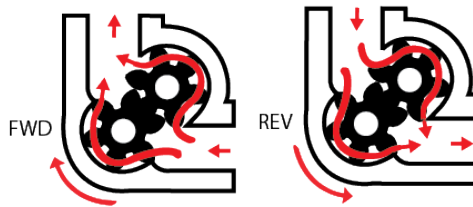

- a. Flush with Cut-back Asphalt. *Bunker fuel is OK in-place of cut-back.*
- b. Off-load all of the emulsified asphalt, draining the tank as dry as possible.
- c. Drain Flush Tank or On the Side Control Panel, select and perform “Empty Flush Tank”.
- d. Re-Fill Flush tank with diesel or a non-water based solvent.
- e. On the Side Control Panel, select and perform “On Load Thru Spraybar Hose A”. Load the tank slowly (40 GPM) with enough material to cover the heat tubes.
- f. On the Cab Console, select “Spread-Heat” and circulate the spray bar for 10-30 minutes. With optional “Front Suction”, select and circulate an additional 5 minutes.

## 2013

- g. On the Cab Console, select “Circulate-Heat” and circulate and for 5 minutes.
- h. Drive the truck around the yard stopping and starting several times.
- i. Now, shut off the truck engine and listen to the tank. When all of the boiling, hissing and popping stops, the water has boiled out.
- j. Off-load the cut-back.
- k. Load Hot Asphalt through the Spray Bar
- l. On the Side Control Panel, select and perform “On Load Thru Spraybar Hose A”. Load the tank slowly (40 GPM) with enough material to cover the heat tubes.
- m. On the Cab Console, select “Spread-Heat” and circulate the spray bar for 10-30 minutes. With optional “Front Suction”, select and circulate an additional 5 minutes.
- n. On the Cab Console, select “Circulate-Heat” and circulate and for 5 minutes.
- o. Now, shut off the truck engine and listen to the tank. When all of the boiling, hissing and popping stops, the water has boiled out, you may continue loading and spreading. *The safest practice at this point is to shoot out the partial load.*
- p.

### Loading Through Valve A

*This method is the fastest and simplest way to load asphalt into the tank.*

---

**WARNING: EXTREME CARE MUST BE USED DURING PUMPING OPERATIONS TO MAKE SURE THAT SYSTEM COMPONENTS OPERATE AT THEIR RATED PRESSURES. FAILURE TO CHECK THE CONDITION OF ALL HOSES AND CONNECTIONS WHEN PUMPING COULD RESULT IN SEVERE BURNS, INJURY OR DEATH FROM PUMPING ERRORS MADE WITH FAULTY COMPONENTS.**

---



# ON LOAD HOSE-A

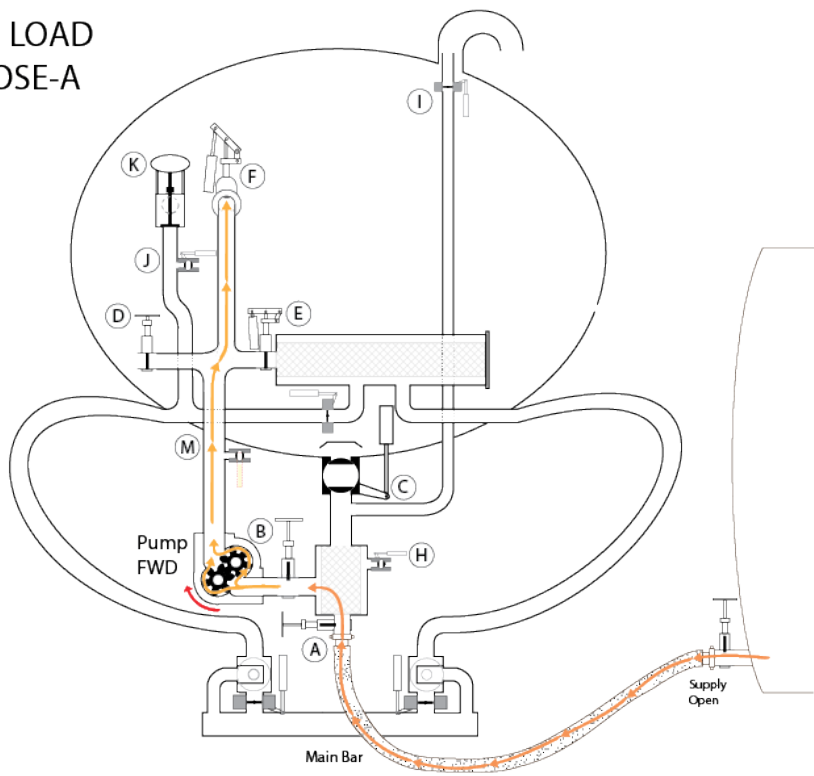

- a. Connect transfer hose (inspect condition) from supply vessel to Valve A.
- b. On Side Control Panel, Select "On Load Hose-A" and pull "Pump/Valves" (red button) to actuate "F" valve.



- c. With pump in "Forward", slowly turn the Manual Increase dial clockwise to 1/4 turn or approximately (40-60 GPM). While observing all connections and the transfer hose, open the "A" valve. Now open supply tank valve. If all is well speed pump up

to desired transfer GPM, (approximately 250gpm) when using a 3” transfer hose. Asphalt will be pulled through Valve A and through valve F to the bottom of tank.

- d. When the desired amount of asphalt has been pumped, shut off the supply.
- e. Loosen the connection at the supply vessel so it will draw in air to suck the hose clear. Do this for three minutes and then remove the hose from the supply vessel, elevating it to help clean it. If you wish, draw some diesel through the hose to help clean it.
- f. Close Valve A.
- g. On Side Control Panel, push “Pump/Valves” (red button).
- h. Zero Manual Increase dial.
- i. Neutral pump direction.

### Loading Through Optional Valve L

Valve “L” (Trough mounted load valve and swivel) has the same function as valve A. It is located at the end of the hose trough on the driver’s side. Because of its location and swivel, the hose can remain attached to the valve and stored in the hose trough.

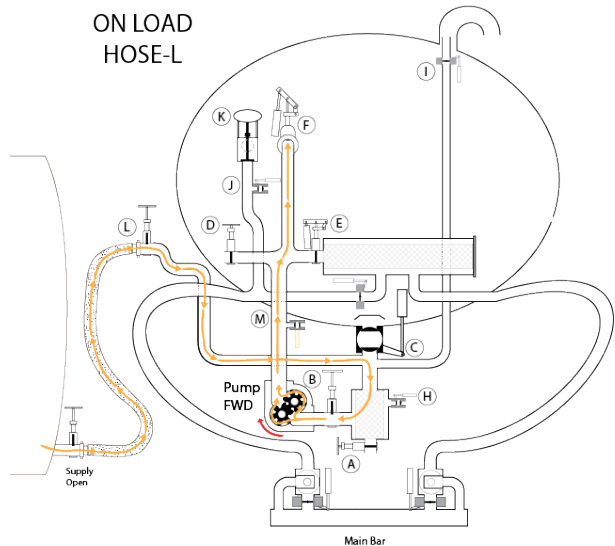



# ON LOAD THRU SPRAYBAR

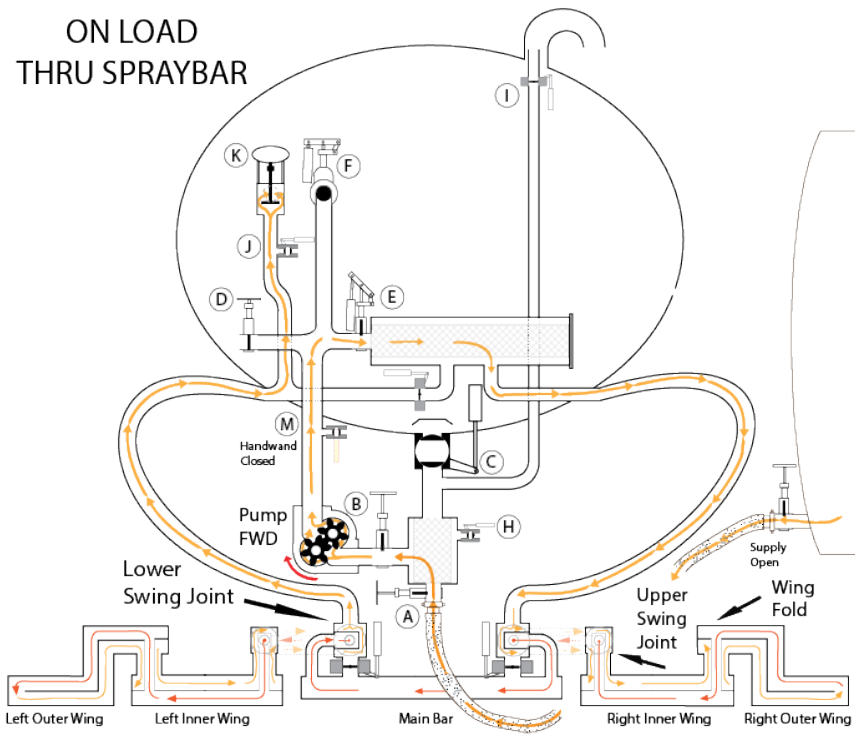

General Operation

## On Load Thru Spray Bar

Loading thru spray bar is safest method for loading hot asphalt into a wet or potentially wet tank. This method is also useful when it is necessary to keep the material in the bar from freezing, as may occur when handling paving grade asphalt in cool weather. It is slower than Method A, being limited to approximately 150 gallons per minute.

- Connect feed hose between Valve A and the supply tank valve.
- On the Side Control Panel, select On Load Thru Spraybar Hose A.
- Pull on the Pump/Valves (red button) to actuate the E & K valves.



## 2013

- d. Select Forward pump direction.
- e. Turn Manual Increase Speed clockwise  $\frac{1}{4}$  turn or about 40-60 GPM.
- f. Open valve A
- g. While observing the hose and the connections, Open supply valve.
- h. If all is well, increase the pump speed to a maximum of 150 gallons per minute. The pump will push asphalt through the spray bar and into the tank.
- i. When the desired amount of asphalt has been pumped, close supply valve.
- j. Loosen the hose connection at the supply valve so it will draw in air to suck the hose clear. Do this for three minutes and then remove the hose from the supply vessel, elevating it to help clean it. If you wish, draw some diesel through the hose to help clean it.
- k. Close Valve A.
- l. On the Side Control Panel, Push the Pump/Valves (red button) to close the E & K valves.
- m. Switch the pump direction to neutral.
- n. Zero the Manual Increase Speed dial.
- o. On the Cab Console, select "Spread Heat" and "Pump FWD" to resume spraybar circulation



## Loading Through Manhole

---

**WARNING:** Extreme care must be used when opening manhole cover to prevent escaping hot gases from contacting the operator. A face shield should be worn. Failure to exercise care and wear a face shield may result in severe burns or death from escaping gases.

---

- a. Open the manhole cover slowly to allow any internal pressure to release gradually. Wear a face shield.
- b. To keep the material being loaded from filling the asphalt pump and the circulation path, make sure Cab Console Valve Selector is set to OFF.
- c. Monitor the filling procedure closely. Do not overfill. Allow space in the tank for expansion when material is heated.
- d. Observe material in tank for signs of boiling which would indicate moisture. If boiling exists, stop filling at  $\frac{1}{4}$  tank or just cover heat tubes and proceed to step e. If no boiling exists, fill to desired level and proceed to step h.
- e. On the Cab Console, select “Spread-Heat” and circulate the spray bar for 10-30 minutes. With optional “Front Suction”, select and circulate an additional 5 minutes.
- f. On the Cab Console, select “Circulate-Heat” and circulate for 5 minutes.
- g. Now, shut off the truck engine and listen to the tank. When all of the boiling, hissing and popping stops, the water has boiled out, you may continue loading and spreading. *The safest practice at this point is to shoot out the partial load.*
- h. *Close manhole lid and secure.*

OFF LOAD  
HOSE D

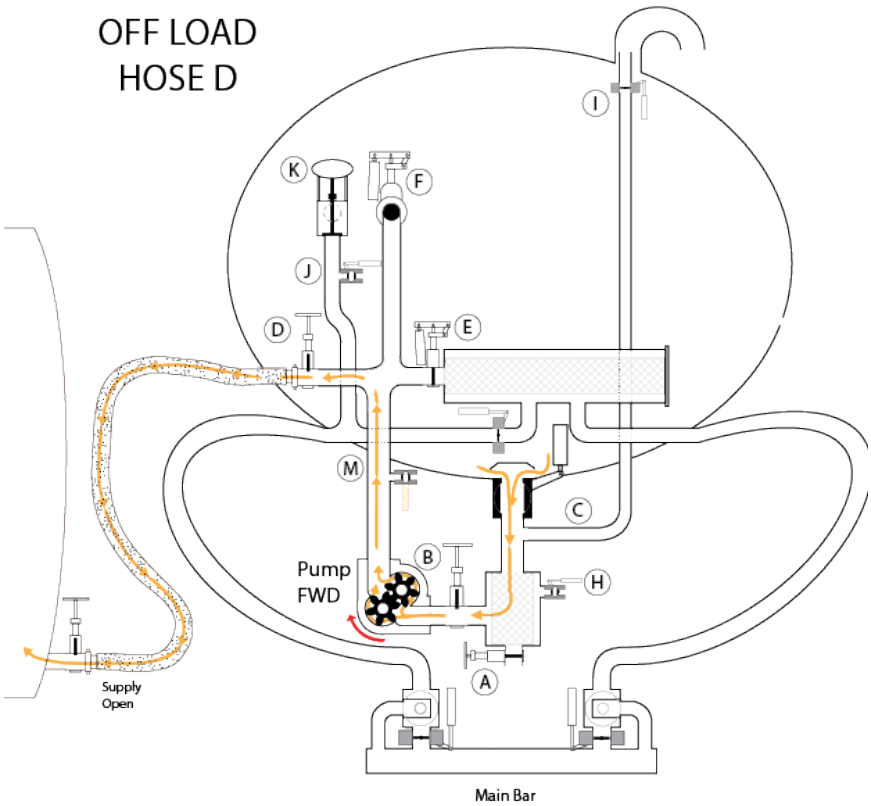

**OFF Load Thru Valve D**

**WARNING:** EXTREME CARE MUST BE USED DURING PUMPING OPERATIONS TO MAKE SURE THAT SYSTEM COMPONENTS OPERATE AT THEIR RATED PRESSURES. FAILURE TO CHECK THE CONDITION OF ALL HOSES AND CONNECTIONS WHEN PUMPING COULD RESULT IN SEVERE BURNS, INJURY OR DEATH FROM PUMPING ERRORS MADE WITH FAULTY COMPONENTS.

- a. Connect transfer hose (inspect condition) from supply vessel to Valve D.
- b. On Side Control Panel, Select OFF Load Hose D and pull "Pump/Valves" (red button) to actuate "C" valve.
- c. Open Valve D.
- d. Open Supply Valve.



- e. With pump in “Forward”, slowly turn the Manual Increase dial clockwise to  $\frac{1}{4}$  turn or approximately (40-60 GPM). While observing all connections and the transfer hose. If all is well speed pump



up to desired transfer GPM, (approximately 250gpm) when using a 3” transfer hose. Asphalt will be pulled through Valve C and pushed through valve D to the supply tank.

- f. When the desired amount of asphalt has been pumped, switch the Pump to Neutral.
- g. Push the red Pump/Valves button.
- h. Close the supply valve.
- i. Pull the red Pump/Valves button.
- j. Switch Pump to Reverse.
- k. Loosen the connection at the supply vessel so it will draw in air to suck the hose clear. Do this for three minutes and then remove the hose from the supply vessel, elevating it to help clean it. If you wish, draw some diesel through the hose to help clean it.
- l. Close Valve D.
- m. On Side Control Panel, push “Pump/Valves” (red button).
- n. Zero Manual Increase dial.
- o. Neutral pump direction.

THRU PUMP  
TRANSFER

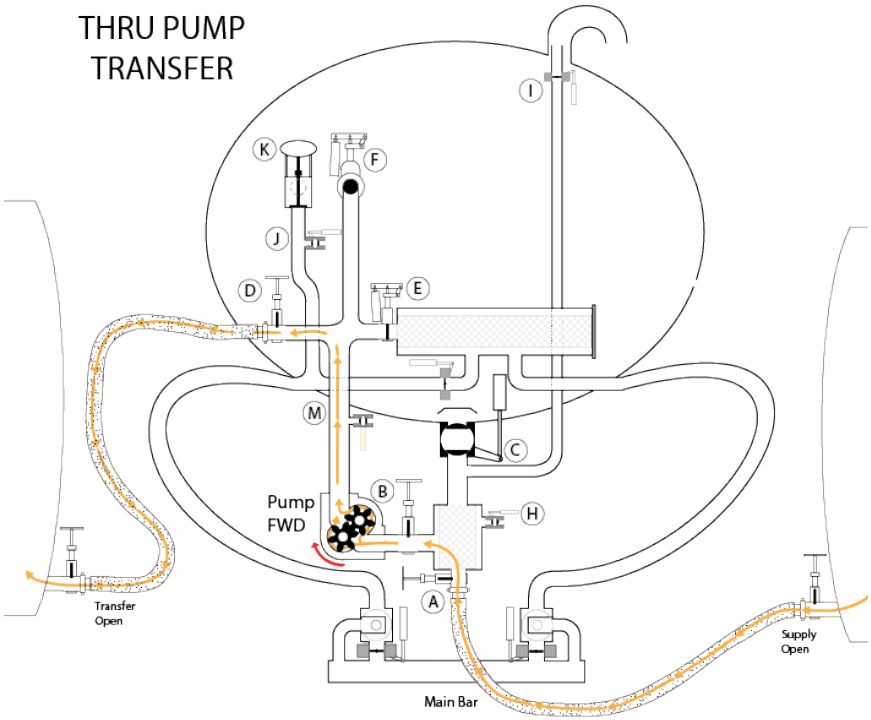

Through Pump Transfer

**CAUTION:**      **INSPECT THE INTEGRITY OF HOSE AND FITTINGS.  
DO NOT TRANSFER ASPHALT WITH A FAULTY HOSE  
OR FITTINGS.**

- a. Connect feed hose between Valve A, and the supply tank valve.
- b. Connect feed hose between Valve D, and the Transfer tank valve.
- c. Open valves A & D.
- d. Open Transfer and Supply Valves.
- e. On the Side Control Panel, select Thru Pump Transfer.
- f. Pull on the Pump/Valves (red button) to actuate pump.



- g. Select Forward pump direction.
- h. Turn Manual Increase Speed clockwise  $\frac{1}{4}$  turn or about 40-60 GPM while observing the hose and the connections.



- i. If all is well, increase the pump speed to a maximum of 150 gallons per minute. The pump will pull asphalt from the Supply Tank and push it to the Transfer tank.
- j. When the desired amount of asphalt has been pumped, close supply valve.
- k. Loosen the hose connection at the supply valve so it will draw in air to suck the hose clear. Do this for three minutes and then remove the hose from the supply vessel, elevating it to help clean it. If you wish, draw some diesel through the hose to help clean it.
- l. Close Valve A.
- m. On the Side Control Panel, Push the Pump/Valves (red button) to stop Pump.
- n. Switch the pump direction to neutral.
- o. Zero the Manual Increase Speed dial.
- p. Close the Transfer Valve.
- q. On the Side Control Panel Select OFF Load Hose D.
- r. Pull on the Pump/Valves (red button) to actuate C valve and pump.
- s. Select Reverse pump direction.
- t. Turn Manual Increase Speed clockwise  $\frac{1}{4}$  turn or about 40-60 GPM while observing the hose and the connections.

## 2013

- u. Loosen the hose connection at the Transfer valve so it will draw in air to suck the hose clear. Do this for three minutes and then remove the hose from the supply vessel, elevating it to help clean it. If you wish, draw some diesel through the hose to help clean it.
- v. Close Valve D.
- w. On the Side Control Panel, Push the Pump/Valves (red button) to stop Pump.
- x. Switch the pump direction to neutral.
- y. Zero the Manual Increase Speed dial.
- z. On the Cab Console Select Auto Flush then switch Pump to FWD.

### EXTERNAL PUMP TRANSFER

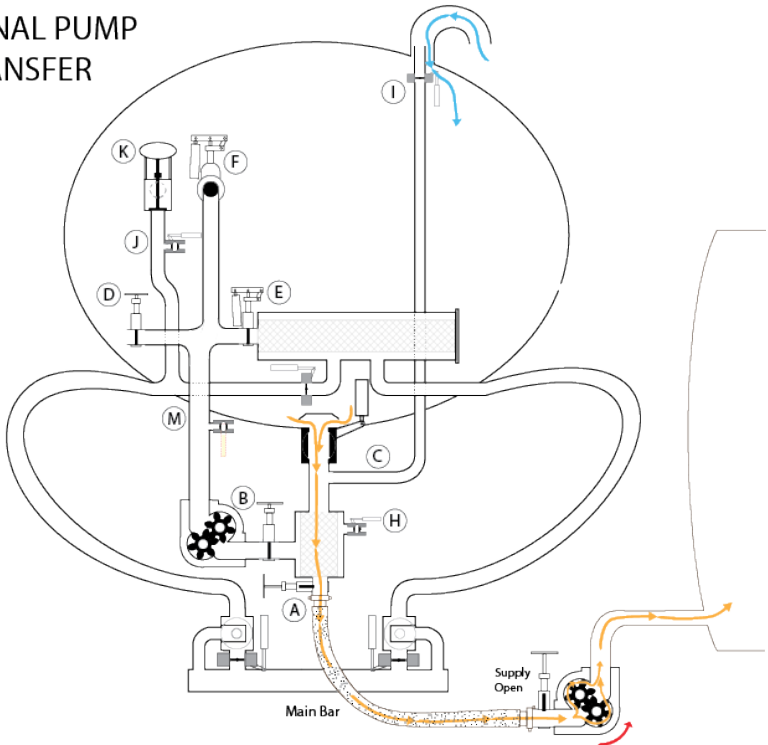



## Gravity OFF Load (External Pump Transfer)

a. Connect transfer hose (inspect condition) from supply vessel to Valve A.

b. On Side Control Panel, Select Gravity OFF Load and pull “Pump/Valves” (red button) to actuate C valve.



c. Start External Transfer Pump.

d. Open the “A” valve.

e. When the desired amount of asphalt has been pumped, push the red Pump/Valves button to close valve C.

f. Close Valve A.

g. Loosen the connection at valve A so it will draw in air to suck the hose clear. Do this for three minutes and then remove the hose from the supply vessel, elevating it to help clean it. If you wish, draw some diesel through the hose to help clean it.

CIRCULATE-HEAT  
(TANK CIRCULATION)

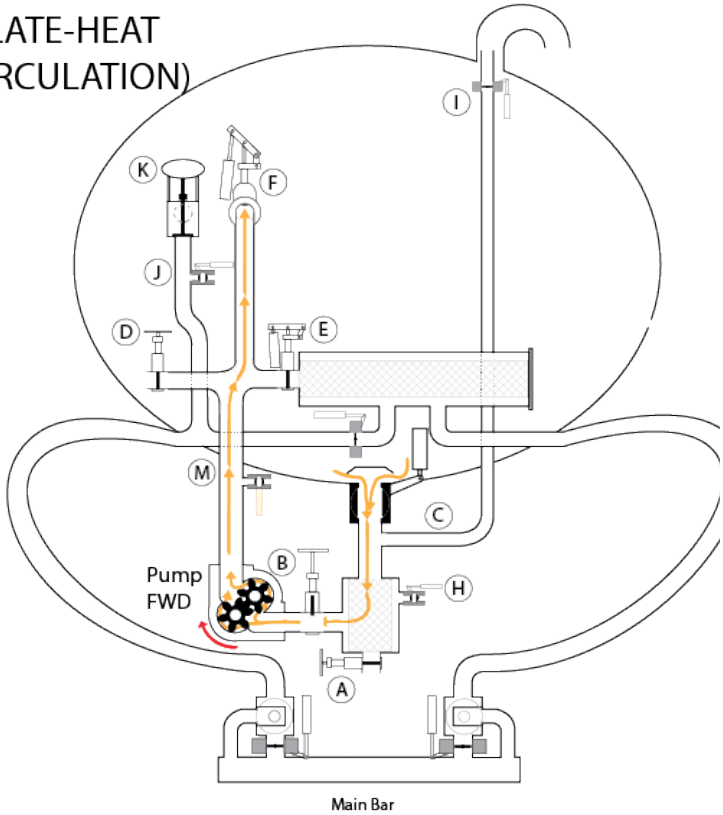

Heating Asphalt

NOTE: Before starting the heaters, position the vehicle broadside to the wind to allow the wind to carry emitted vapors away from the hot exhaust stacks of the heater and the truck engine air intake.

---

**WARNING: POTENTIAL FIRE OR EXPLOSION HAZARDS EXIST WHEN OPERATING THE BURNERS. FAILURE TO FOLLOW THE BURN OPERATION SAFETY PROCEDURES COULD RESULT IN SEVERE BURNS, INJURY OR DEATH.**

---

- **ALWAYS** use the auto ignition switch or a hand torch to ignite a burner. NEVER use a match or lighter,
- **ALWAYS** make sure flues are covered by at least 6-inches (152 mm) of material before heating,
- Burners should **NEVER** be operated under the following conditions:



1. Material level is below heat tubes.
  2. During pumping operations.
  3. While the vehicle is unattended.
  4. While the vehicle is in motion.
  5. When the vehicle is parked in a confined area.
- **NEVER** remove materials from the tank while the burners are operating, or the automatic burner controls are set to operate.
  - **NEVER** remove materials from the tank within 20 minutes of heating. Hot heat tubes can ignite vapors when exposed to oxygen.

## Tank Circulation While Heating

### Warm Asphalt

- a. On Cab Console select “Circulate Heat”.
- b. Select Pump “FOR” (forward).
- c. Select “Manual”.
- d. Use the GSY switch “INC” to set pump speed at 150 GPM.
- e. As you leave the cab, be sure the parking brake is set and the asphalt tank gauge reads above the fire line.
- f. Open exhaust stack
- g. Start burners as needed.
- h. Do not allow the asphalt temperature to exceed the maximum recommended by the supplier

### Cold Asphalt (too stiff to circulate)

- a. Check the parking brake is set and the asphalt tank gauge reads above the fire line.

## 2013

- b. Open exhaust stack.
- c. Start burners as needed.
- d. Monitor temperature to circulate as soon as possible.
- e. Follow instructions for warm asphalt circulation above.

**CAUTION:** TO AVOID EQUIPMENT DAMAGE, HEAT THE MATERIAL SLOWLY IF MOISTURE IS PRESENT IN THE TANK. THE MATERIAL TEMPERATURE WILL NOT RISE ABOVE 212°F UNTIL THE MOISTURE IS GONE.

*Do not circulate material in the spray bar at first. As much as 20% of the heat developed in the asphalt can be dissipated due to heat losses in the spray bar.*

### Heating with Diesel Fired Burners

---

**WARNING:** POTENTIAL FIRE OR EXPLOSION HAZARDS EXIST WHEN OPERATING THE BURNERS. FAILURE TO FOLLOW THE BURN OPERATION SAFETY PROCEDURES COULD RESULT IN SEVERE BURNS, INJURY OR DEATH.

---

- a. Open lids on top of exhaust stacks.
  - b. Make sure MASTER switch is off.
- 

**WARNING:** If a burner goes out, do not attempt to re-light it for at least two (2) minutes. This will allow the vapors to dissipate from the flue. Flip the switch to the “Cool-Down” position during this time. Failure to comply could result in a potential explosion hazard and cause severe burns, injury or death.

---

**NOTE:** *The burners must be turned on sequentially as listed in steps c and d.*

- c. Turn R. or LOWER BURNER switch ON. Burner will ignite automatically.
- d. Turn L. or UPPER BURNER switch ON.
- e. Monitor the temperature gauge. Do not allow the asphalt



temperature to exceed the maximum recommended by the supplier.

### Spray Bar Circulation while heating

- On Cab Console select “Spread-Heat”.
- Select Pump “FOR”.
- Select “Manual”.
- Use GSY “INC” switch to increase pump speed to 150 GSY.

### Check Equalizers

*If an equalizer valve is open, a plug of asphalt can form in the spray bar and prevent material from circulating.*

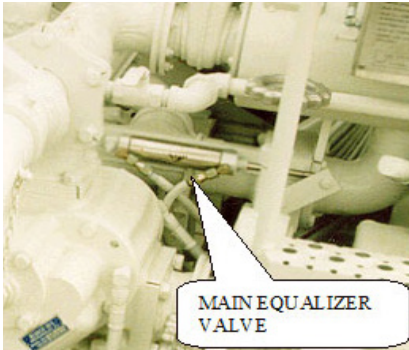

- Visually verify that all three equalizer valves are closed. The actuating rods on the pneumatic cylinders that drive the valves must be fully extended.
- Turn CRC unit ON and set CRC/manual switch to manual.
- Run pump in FORWARD and adjust speed for approximately 80 gallons per minute.
- After a minute or two touch the ends of the spray bar. It should be warm, indicating that adequate circulation is taking place.

(The cylinder shaft is extended)



Equalizer Valve Closed

Spraying Operations with CRC Computerized Rate Control

---

**WARNING:** BEARCAT EQUIPMENT USES VOLATILE MATERIALS AT HIGH TEMPERATURES AND PRESSURES. THIS EQUIPMENT EMPLOYS HIGHLY COMBUSTABLE OR EXPLOSIVE FUELS. POTENTIALLY LIFE-THREATENING HAZARDS MAY EXIST DURING EQUIPMENT OPERATION. PERSONNEL MUST BE FAMILIAR WITH SECTION 2 (SAFETY PRECAUTIONS) BEFORE OPERATING BEAR CAT EQUIPMENT.

---

**WARNING:** POTENTIALLY LIFE-THREATENING HAZARDS MAY EXIST DURING EQUIPMENT OPERATION. ONLY QUALIFIED PERSONNEL SHOULD ATTEMPT TO OPERATE, SERVICE OR MAKE ADJUSTMENTS TO THE BEARCAT EQUIPMENT.

---

- a. At job the site, with the engine idling, turn cab console power switch on. With control panel turned on, the display will show a Warning. Read and comply with the instructions given. Press OK to continue.
- b. Switch Master OFF, Selector Switch OFF, Pump OFF.
- c. Engage the PTO.
- d. With Selector Switch select Spread Heat. Listen for and check that valves C and E have opened.
- e. Switch CRC.
- f. Switch Pump Forward. (Circulation should start and GPM should indicate Idle speed).
- g. Once Spraybar is warmed up, unlatch Spraybar and lower wings.
- h. (With Master OFF), Switch appropriate spray valve switches on.
- i. Use the Taper Cut switches to select the same spray valves on the display.
- j. With the GSY Switch, select the desired spread rate indicated in GSY on the display.



- k. Position the truck for spraying. (Back over the start line until rear tires are at the start line).
- l. When ready, momentarily push down on the Master Switch to activate "Ready".
- m. Start roll and turn on Master Switch as Spraybar passes over start line. (This might take a little practice).
- n. During the shot, you may increase or decrease speed, you may also change bar width, you can also change spread rate. You must however, monitor the GPM as to not over-speed the pump's capability; (this will affect your application rate).
- o. As you get to the end of the shot, have your finger ready on the Master Switch and roll past the stop line turning OFF the Master Switch as the Spraybar passes over the stop line. *Starting or stopping the spray while stopped or not moving will result in zero GPM and cause the spray pattern to drizzle or streak, you must have movement.*

### SPREAD-HEAT (SPRAY)

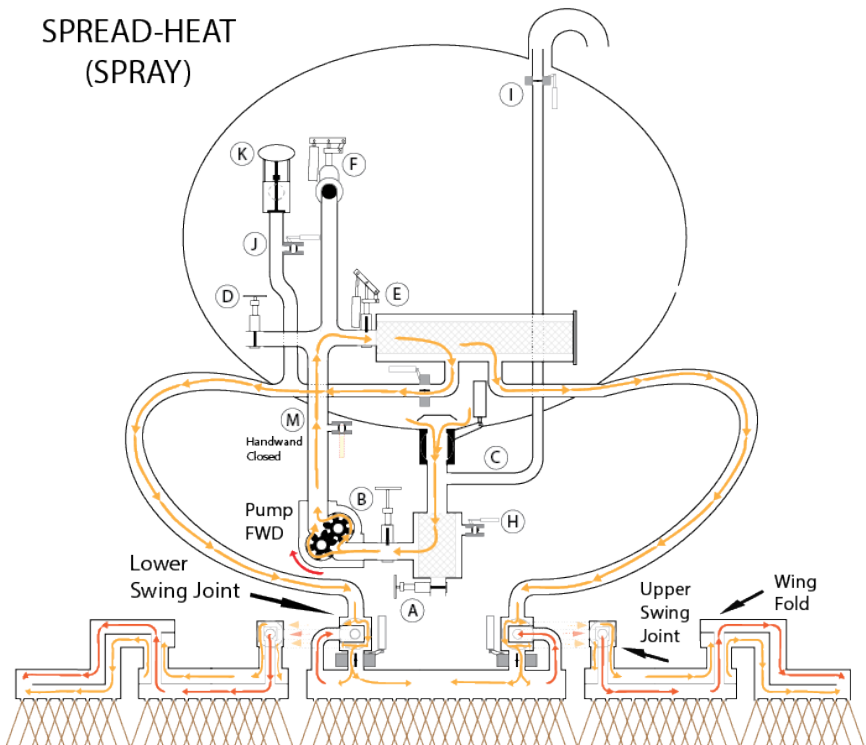

## Spraying Operations using the optional Front Suction

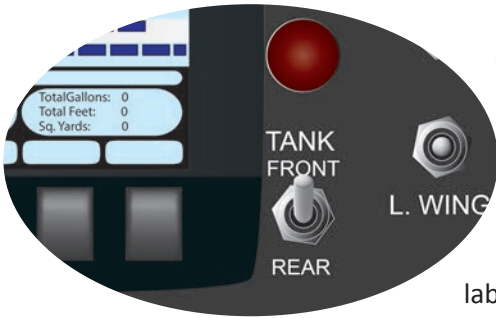

With the optional Front Suction or “G” valve, you can spread while spraying down a steep incline. The G valve draws from the (bottom front) of the tank.

With this option there is a switch on the Cab Console labeled Front Suction, choose Front or Rear.

SPREAD-HEAT  
FRONT SUCTION  
(SPRAY)

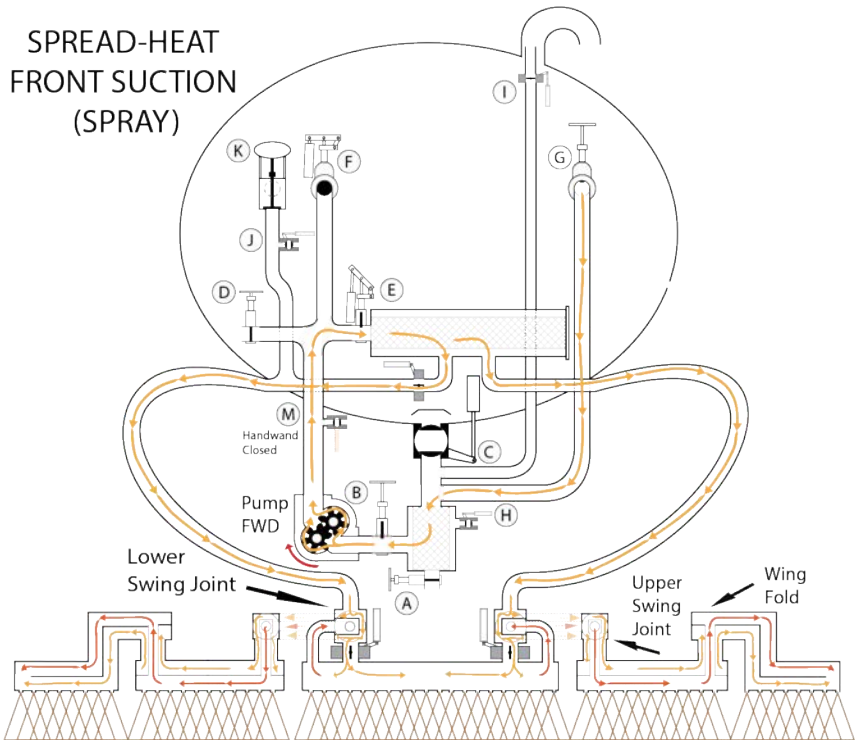



## Setting Spread Rate Manually

- Use the BearCat Road Oil Spreading Calculator to set the spread rate manually.
- Determine the job requirement. For this example, we will assume it to be 0.4 gallon per square yard (GSY), to be spread over an area 12 feet wide and 1300 feet long.
- Determine a suitable speed for the truck. In this case, assume that the chip spreader following you is limited to a speed of 400 feet per minute (4.5 mph). At this point, drive the truck to determine which gear and what RPM it takes to achieve 400 FPM (RPM needs to be in the 1000-1200 range to deliver adequate hydraulic power).
- Refer to Side 1 of the Road Oil Spreading Calculator. At the top of the calculator, align TRUCK SPEED (400 feet per minute) with SPREADING RATE (0.4 gallon per square yard).
- On the BAR LENGTH scale, locate 12 feet (the desired spreading width) and immediately above it, read the PUMP OUTPUT in gallons per minute. In this example, it is 215 GPM.
- On Side 2 of the Calculator, set the SPREADING RATE (0.4 gallon per square yard) at the BAR LENGTH ( 12 feet). Read the OIL REQUIRED in gallons opposite DISTANCE TO BE SPRAYED. Since in this example the latter is 1300 feet, the Calculator indicates that the amount of oil required is 700 gallons.
- On the Cab Console,
- Check Master OFF, Selector Switch OFF, Pump OFF.

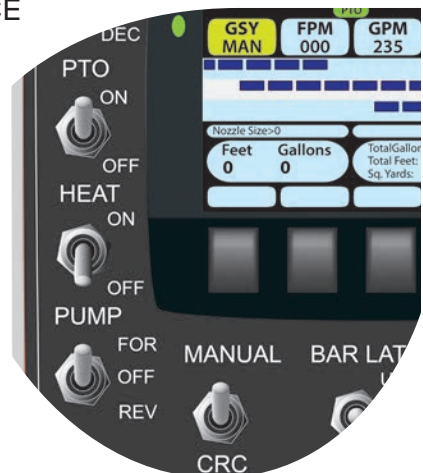

## 2013

- i. With Selector Switch select Spread Heat. Listen for and check that valves C and E have opened.
- j. Switch to MANUAL.
- k. Switch Pump Forward. (Circulation should start and GPM should indicate Manual speed).
- l. (With Master OFF), Switch appropriate spray valve switches on.
- m. Use the Taper Cut switches to select the same spray valves on the display.
- n. With the transmission in neutral, hold the engine RPM at the pre-determined RPM to maintain 400 FPM. With the GSY Switch, select the desired GPM (215 GPM) on the display.
- o. Position the truck for spraying. (Back over the start line until rear tires are at the start line).
- p. Start roll and turn on Master Switch as Spraybar passes over start line.
- q. Quickly advance to the pre-determined RPM or 400 FPM and maintain this speed.
- r. During the shot, monitor the GPM and make adjustments.
- s. As you get to the end of the shot, have your finger ready on the Master Switch and roll past the stop line turning OFF the Master Switch as the Spraybar passes over the stop line.

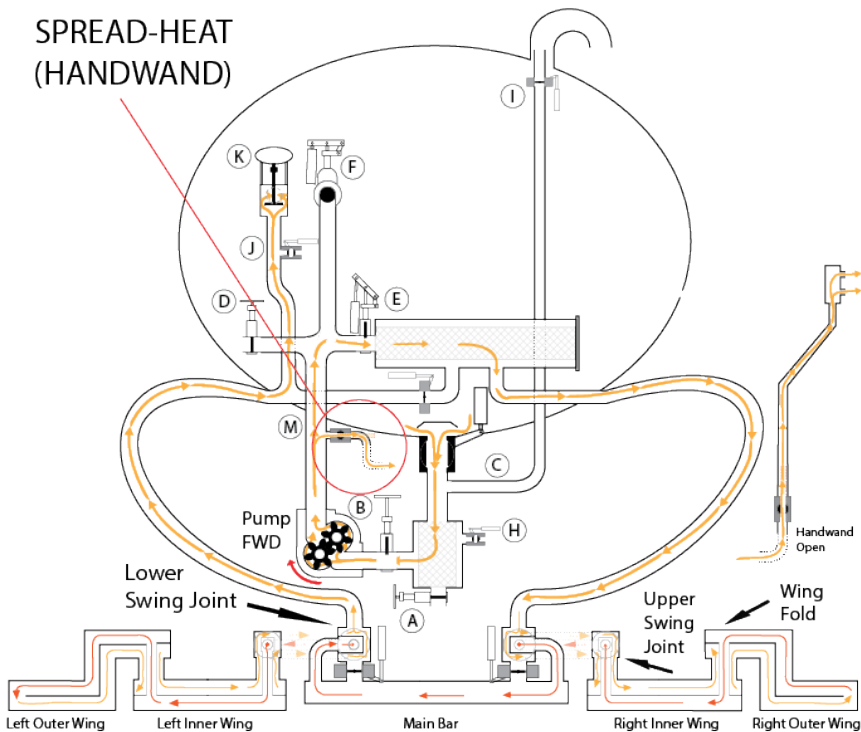

## Hand Spraying While Circulating Spraybar

During the course of normal CRC spreading, on occasion there is a need for quick patch work. You have just finished a normal shot in CRC and need a little hand spraying.

- a. On the Cab Console, switch to Manual.
- b. *Switch Pump to FOR.*
- c. With the GSY Switch select 50 GPM.
- d. Remove the Hand Wand.
- e. Open Valve M.
- f. Open the Hand Wand (Handle Valve) to spray.
- g. Use the GSY switch to increase or decrease pressure as needed. *Use only enough pressure as necessary.*

## 2013

- h. *When finished spraying, on Cab Console switch Pump to REV.*
- i. *Open the Hand Wand Handle Valve to suck air through the hose to clear.*
- j. *With the Hand Wand Handle Valve open, use the wash down hose to spray diesel into the nozzle of the Hand Wand while sucking back.*
- k. *Close Hand Wand Handle Valve and replace Hand Wand.*
- l. *Close Valve M.*
- m. *On Cab Console return Pump to FOR.*
- n. *Switch to CRC.*

## Hand Spraying

- a. On the Cab Console.
- b. Select Load Outside.
- c. Remove Hand Wand and uncoil needed amount of hose.



- d. On the Side Control Panel, select OFF Load Hose D.
- e. Pull Pump/Valves (red button) to actuate valve C (Do Not Open Valve D).
- f. Switch Pump to Forward.
- g. Turn Manual Increase speed CW from zero 1/8 turn or until pump starts to rotate about 10 GPM.
- h. Open valve M.
- i. *Open Hand Wand Handle Valve to spray.*
- j. *Adjust Manual Increase dial to desired pressure. Use only enough pressure as necessary.*



HAND WAND  
(VALVE M)

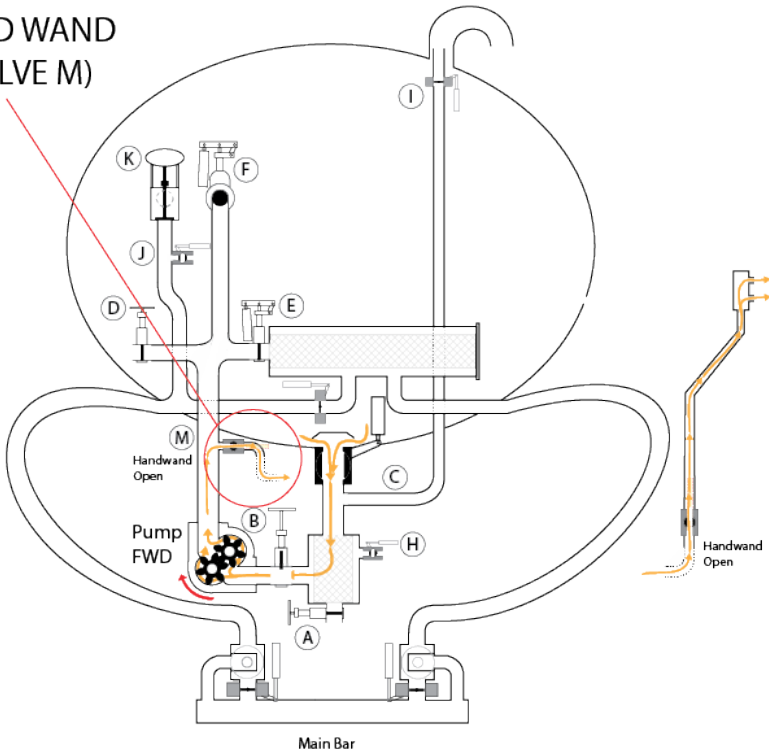

- k. *When finished, on Side Control Panel, switch Pump to Reverse.*
- l. *Open Hand Wand Handle Valve to suck back material.*
- m. *With the Hand Wand Handle Valve open, use the wash down hose to spray diesel into the nozzle of the Hand Wand while sucking back.*
- n. *Close Hand Wand Handle Valve and replace Hand Wand.*
- o. *Close Valve M.*
- p. *On Side Control Panel, push Pump/Valves (red button) to close valve C.*
- q. *Zero Manual increase dial.*
- r. *Switch Pump to Neutral.*

## Spray Bar Flushing

1. Check Flush Tank fluid level.
2. With Spraybar warm and circulating...
  - a. Check Master Switch OFF.
  - b. Switch Pump OFF.
  - c. Select Auto Flush.
  - d. Switch Pump FWD.

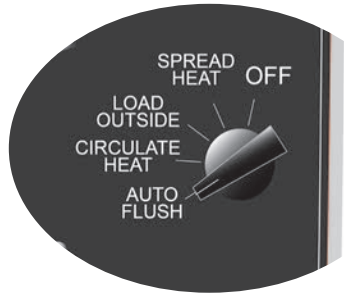

Display should indicate GPM.

### Stage 1

Uses forced air to push asphalt from Spraybar back to Tank. This process automatically actuates valves E, I, and K, and runs the pump at high speed to evacuate the system. After 5 minutes of purging the system switches to stage 2.

### AUTO-FLUSH STAGE 1

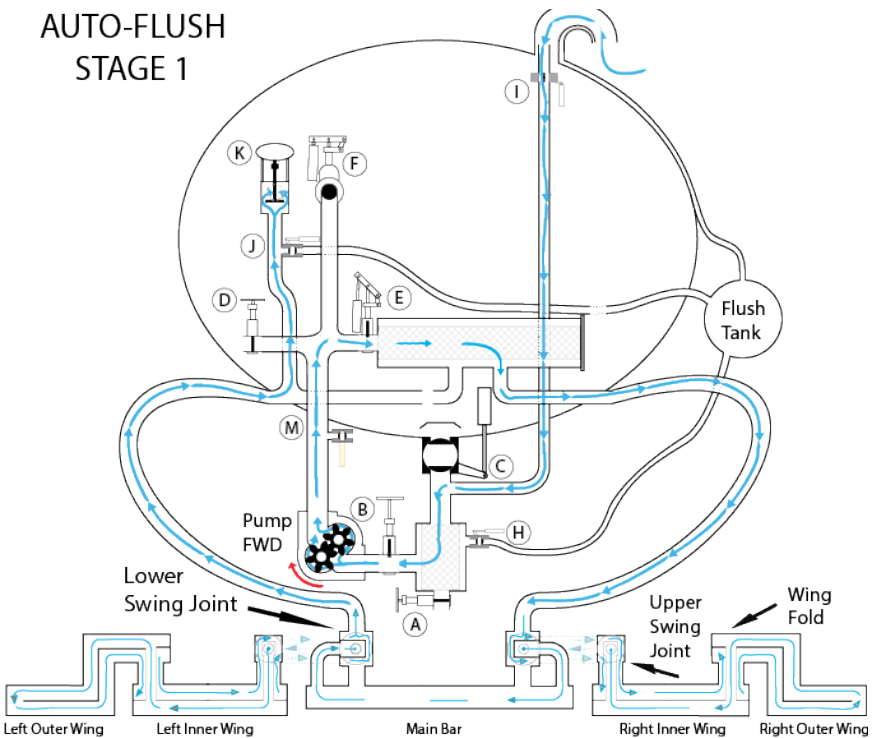



## Stage 2

Actuates valves H, E, and J circulating flush fluid from the Flush Tank at 40 GPM through the Spraybar and back to Flush Tank. After 5 minutes of circulating the system with flush fluid, switches to stage 3. *The circulation time is adjustable.*



## AUTO-FLUSH STAGE 2

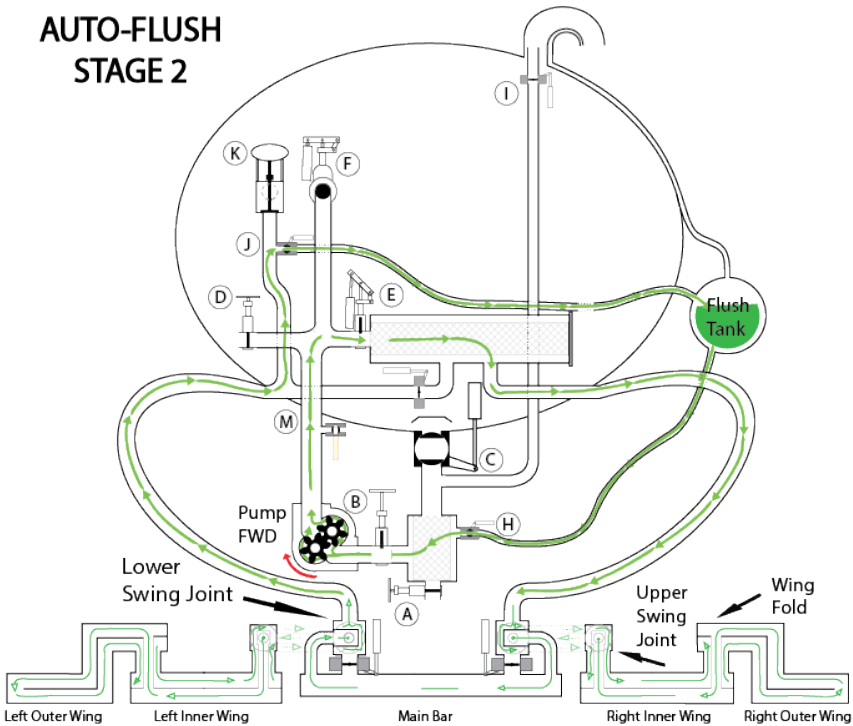

# 2013

## Stage 3

Actuates valves I, E, and J purging the Spraybar of flush fluid with forced air from 40 GPM increasing to high speed. After 5 minutes the cycle is finished, all valves close and the Pump Stops. The Auto Flush is finished.

*The spray bar must be flushed with diesel fuel as described above after each work shift. This avoids the time consuming problems that develop when residual asphalt is allowed to solidify in the spray bar. A quick flush takes less time and is not nearly so tedious as having to free all of the valves in a frozen spray bar!*

### AUTO-FLUSH STAGE 3

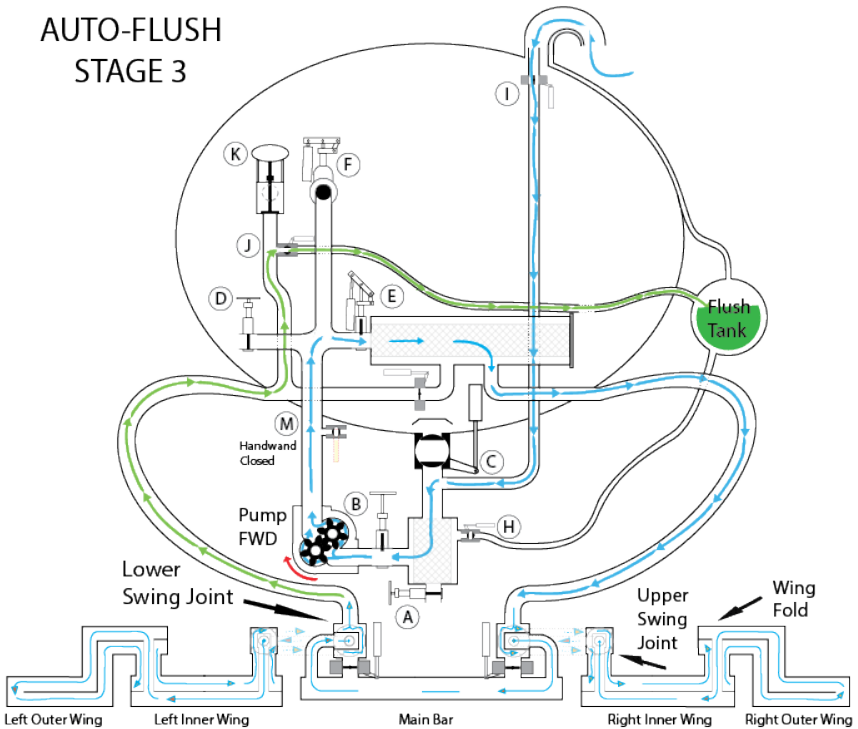

### Empty Flush Tank

When the fuel in the FLUSH FUEL tank becomes too thick with asphalt to flush effectively (check with dip stick on tank cap), you can empty the tank as follows:

- a. On the Cab Console, Select Load Outside.



- b. On the Side Control Panel, select Empty Flush Tank.
- c. Pull Pump/Valves (red button), to actuate E, H, and K.
- d. Switch Pump Forward.
- e. Turn Manual Increase Speed dial to ½ turn (about 100 GPM).
- f. Cycle about 5 Minutes and push red button to stop.
- g. Zero Manual Increase Speed dial.
- h. Switch Pump to Neutral.
- i. Refill Flush Tank.

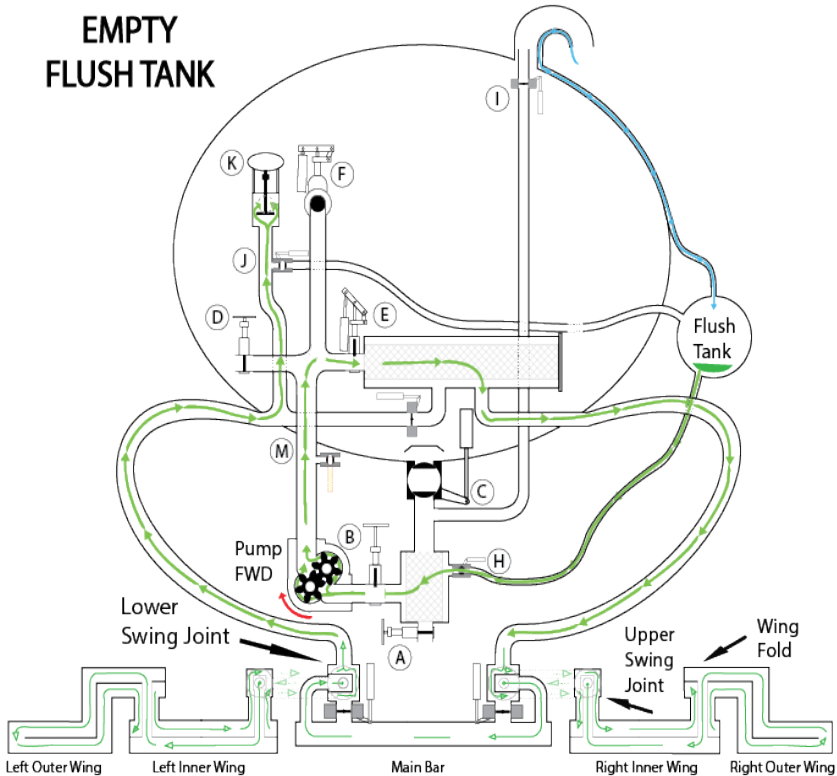

## Shutting the Equipment Down

After Completing the Spraybar Flushing Procedure (Auto Flush),

- a. On the Cab Console select OFF with the Valve Selector Dial.
- b. Switch Pump to OFF
- c. Center the spray bar and raise it to the maximum height. Engage the latches to lock it in place.
- d. Raise the wings fully upright and latch the safety chains.
- e. Lock the reel that holds the hand spray hose and make sure other hoses are secured in place.
- f. Disengage PTO.
- g. Oil on tail-lights will quickly pick up enough dust to impair the effectiveness of the lights.
- h. Wipe the taillights clean of oil film.
- i. Ensure valves A,B, D, M, L, and Hand Wand Handle Valve are closed. At this point ALL valves should be closed.
- j. Power the Cab Console OFF.



SHUT DOWN  
(Closed)

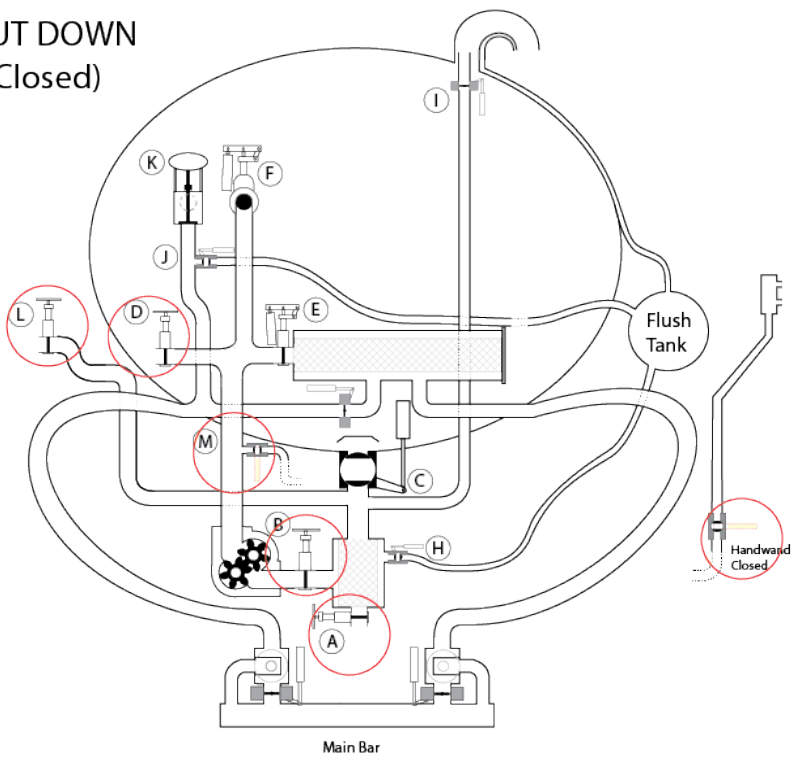

General Operation

# 2013 CONSOLE DISPLAY

## Start Up

Press and hold the Power switch up until the screen lights up then release the switch. After a few seconds a warning will display. It is important to read and understand the condition

of your truck. If your truck is wet or the spraybar and tank contain moisture left over from shooting emulsion and you are about to circulate or load hot asphalt (200 + degrees), a serious danger to you and people near the truck exists. If your tank is loaded with hot asphalt and your spraybar and plumbing is wet, circulating the spraybar will cause an eruption. Tank eruptions can blow tanks apart killing people and creating a huge mess. If you are in a situation with a loaded tank of hot asphalt and are unsure of the condition of the spraybar or know it is wet, use another truck to off-load the tank or take it back to the plant and off-load. Then follow the procedures for loading thru the spraybar to dry it out.

To continue press the button below OK.

The Display has four buttons at the base that control different functions based on the current page or activity. Some functions that require an increase or decrease of an integer can be changed with the appropriate button or the GSY Inc/Dec switch.



The four lights (2 red & 2 green) to the right and left of the screen, all flash as a warning for the warning screen but have different meanings for normal operation.





The upper right green light indicates Manual Operation and/or Simulate FPM is on.

The lower right red light indicates over speeding the asphalt pump.

The upper left green light indicates the Master switch is on.

The lower left red light indicates a system fault.

The large Error light to the right of the Display also comes on when either of the small red lights come on to alert the operator.

## Home Page

After power up and the Warning page, Home page is the default screen for spreading operations

### GSY

Spread Rate measured in Gallons per Square Yard is the controlled application rate. The rate can be changed when the window is selected (yellow). Use the button below the “select” icon to select the GSY window, then use the inc/

dec switch to set the desired rate. The four buttons at the bottom correspond to the windows above.

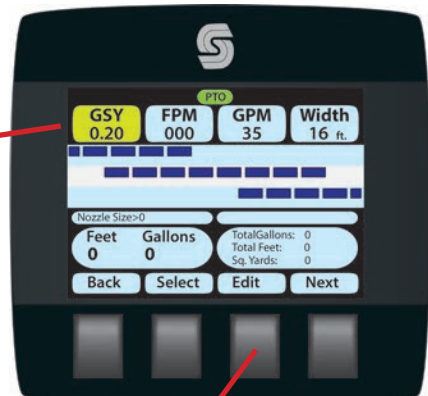

Display



Another method to change the rate is (GSY window selected), push the button below the “Edit” icon to enter edit mode. Use the “UP & DOWN” buttons to select the desired rate, then press “OK” to save and exit edit mode.

## 2013

### FPM

Travel speed in Feet Per Minute is indicated when ever the truck is moving in forward or reverse. A sensor mounted in the differential picks up ground speed off the ring gear.

### PTO

(Power Take Off) Turns green when engaged or on.

### GPM

Asphalt pump speed is measured in Gallons Per Minute. When ever the pump is turning forward or reverse, manually or in CRC, GPM is indicated. A sensor mounted in the hydraulic motor picks up the pump speed.

### Width

A Total of the number of Spray Valves selected on using the Taper Cut Switches or selecting the Spray Valve Switches.

### Nozzle Size

A calculator that determines the optimal nozzle size based on the indicated GSY and FPM. Use this reference to operate within the optimal range of the nozzles currently mounted in the spraybar by speeding up or slowing down. If the optimal speed for the current nozzles doesn't suit, then change nozzles. Nozzles only affect spread Rate when you spread to fast and the increased bar pressure causes bypass. For instance, if you are using #2 nozzles and while spraying the Nozzle Size indicator reads 3 or 4, you are going to fast. Either slow down or change nozzles. Going too slow only affects the nozzles ability to fan properly resulting in streaking. If streaking is a problem, reduce nozzle size.

### Taper Switch selection

The center of the display shows the current on or off status of the Taper Cut selection. Solid blocks indicate ON, Hollow blocks indicate OFF. The display only represents the Taper Cut Switch selection. It does not represent the Spray Valve Switches on the Console. Both the Taper Cut AND the Spray Valve Switches have to be ON for any given valve to spray. The Width always calculates the total number ON. Use the Taper switches on the Console to select and de-select.



Left Wing    Main Bar    Right Wing



Notice that all the Spray Valve switches are turned on yet the Width indicates 9 ft. The Taper Cut has been deselected or turned OFF from the left on the display. The same result in width can happen if all the Taper Cuts are ON but the Spray Valve switches are OFF.

### Gallons

When the Master switch is On, gallons used is indicated in the left window. This number will reset every time the Master switch is turned On.

### Total Gallons

While spreading the computer accumulates the (Spread Rate X Width X distance sprayed) and keeps a running total. Press Select until Gallons Used is highlighted, then press and hold Reset to zero the counter.

Display

# 2013

## Feet

In the left window, distance is measured when the Master switch is turned On. This measurement is reset every time the Master switch is turned On.

## Total Feet

While spreading the computer accumulates the distance sprayed and keeps a running total. To reset, Select and hold Reset until zero.

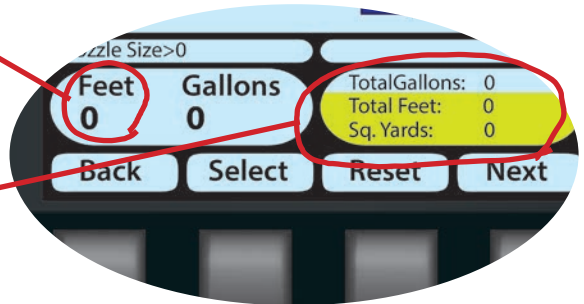

## Sq. Yards

While spreading the computer accumulates the (Width X distance sprayed) and keeps a running total. Press Select until Feet Spread and Sq. Yards is highlighted, then press and hold Reset to zero the counter. Both Feet Spread and Gallons used reset at the same time.

## Settings Page

Press the Next button to access the Settings Page. Next and Back buttons are for changing pages.

Adjustments in the Settings Page can be accessed by pushing the Select button (repeatedly) and highlighting the appropriate window for adjustment. When a window has been highlighted press Edit and the four selector buttons change for making adjustments.

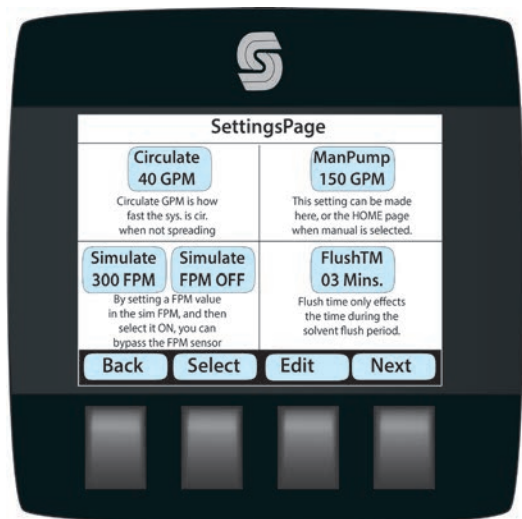



### Circulate

With the Master switch OFF, the spray system and plumbing is valved to circulate. When circulating in CRC, the pump is turning at Idle or Circulate speed. By highlighting Circulate you can use the Up and Down buttons to change to the desired speed. Press OK after changing speed to save your settings and exit edit mode.

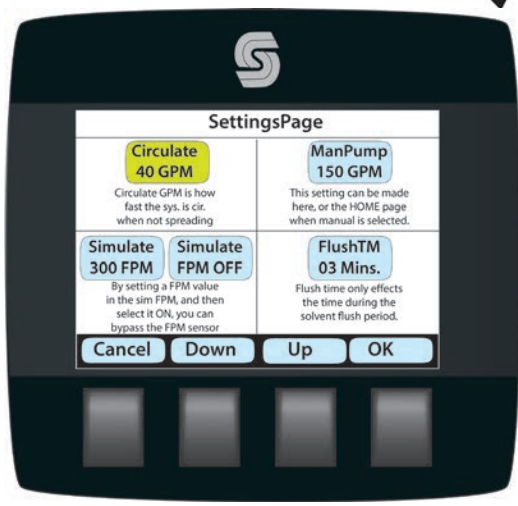

### Manual

(ManPump) on the settings page is for setting the pump speed in manual operation. On the Console when the "Manual/CRC" switch is set to Manual, the pump turns at the preset speed in the direction indicated by the Pump switch.

By highlighting ManPump and pressing Edit, you can change the speed with the Up and Down buttons or with the GSY Inc/Dec switch on the Console. Press OK to save and exit edit mode. Press the Back button to return to the Home Page and the GSY now indicates MAN for spread rate. The Manual pump speed can be

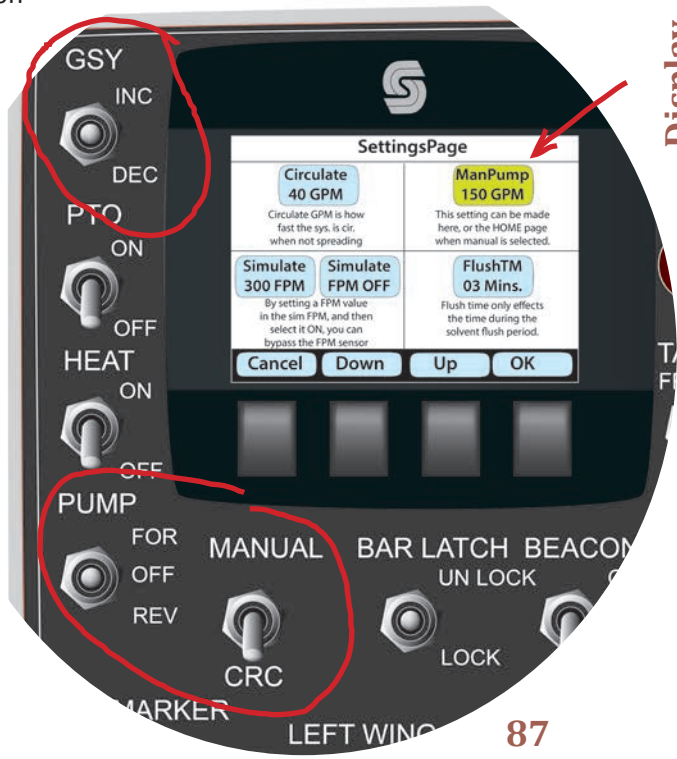

Display

## 2013

seen as indicated in GPM. Manual pump speed can also be accessed on the Home Page by simply selecting Manual with the Manual/CRC switch on the Console. Use the GSY Inc/Dec to change speed. Having the ManPump setting pre-set to 100-150 GPM, can help in the event of a plugged Poppet valve or Spraybar collision damage. Simple switch to Manual and reverse the pump to suck back the Spraybar and stop any spillage. Be sure to switch back to CRC when finished. If Manual spreading is not the desired operation, It can be costly and embarrassing when you return to work and your spreading the wrong application rate because you left it switched to Manual. Don't forget the Pump direction as well.

### Simulate FPM

Simulate FPM is a Diagnostic tool for testing components that are FPM driven like GPM in CRC mode. By selecting Simulate FPM and pressing Edit, you can change the speed. To actuate this feature select Simulate FPM OFF and toggle On/Off to On.

By pressing Back to return to the Home Page you can see that the FPM indicates the simulated speed regardless of actual speed. Be sure to return the Simulate speed to OFF when finished as this can affect spread rate when returning to work.

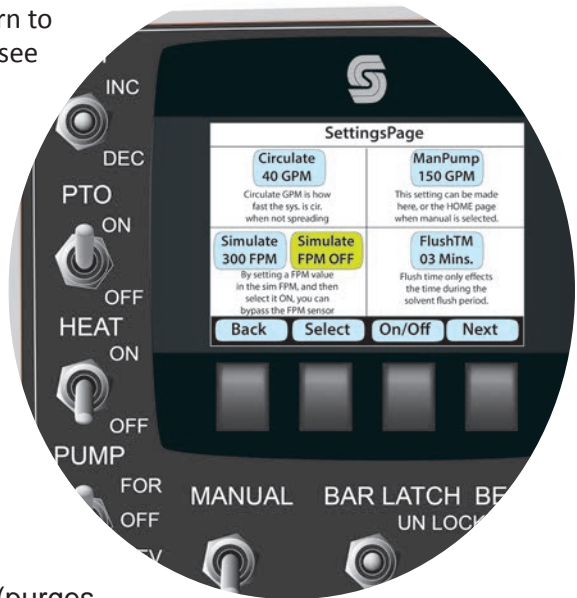

### Flush Time

During the Flush cycle there are 3 processes.

- Flush Cycle 1 (purges asphalt from the spraybar).
- Flush Cycle 2 (circulates solvent from the Flush Tank thru the spraybar and back to Flush Tank). During this cycle the spray valves can be operated if desired.
- Flush Cycle 3 (returns solvent back to Flush Tank).



During Flush Cycle 2, the time the solvent circulates in the spraybar can be adjusted up or down by selecting FlushTM pressing Edit and raising or lowering the time with the Up or Down buttons. Press OK to save and exit edit mode. If you are spraying paving grade asphalt you may want to increase the circulate time for better or more thorough flushing.



## Spraybar Setup

Factory settings page used in the initial setup of the spraybar or if any changes are made to the spraybar. For instance, if you added a section to a wing or exchanged a computer and the replacement wasn't set properly to match

your spraybar. In order to activate functions on this page the controls and hardware must be physical mounted to your machine.

### Width

Press select to highlight width and use the Up/Down buttons to set the over all spraybar width. Line Markers are added separately. Press OK to save and exit.

### Line Markers

Select Line markers and use the On/Off button to toggle this option on or off.



## 2013

### Wing Sections

Set the wing increments as the number of controlled feet in between wing folds. The diagram above the wing windows shows the layout of the wings in accordance to the windows. It is important to set the wings properly so the limit switches are turning off the correct valves when a wing is lifted.

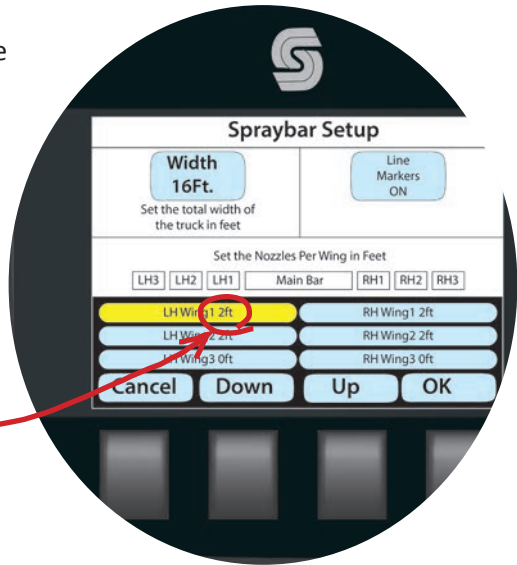

### Calibration Page

Additional factory settings and adjustment features.

#### F-Cal

(Footage Calibration) used to calibrate distance and speed monitoring equipment on the machine. When Spread Rate is a calculation of (gallons/(length x width)), in order for the machine to spread accurately it must be calibrated accurately.

- On a smooth straight surface, accurately measure a distance of 1000 ft. and mark the start and finish so it can be visible from the cab of the distributor.
- Position the distributor on the start line. Pick a reference point on the tire or bumper that can be lined up with the start line.
- On the Home page of the display, select Feet spread/Sq. Yards and press and hold Reset until it reads zero.

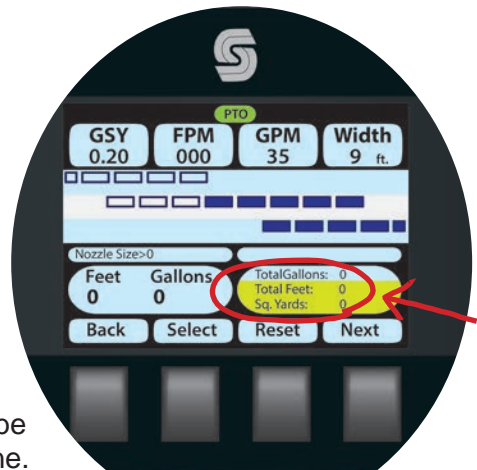



- d. Turn OFF all Spray Valve Switches or turn the Valve Selector Dial Off.
- e. Turn On the Master Switch and drive the pre-measured distance. Speed is not a factor so drive slow and strait. Upon approaching the finish line slow down and turn Off the Master Switch when your reference point lines up with the finish line. At this point the Feet Spread should read 1000 ft. or the pre-measured distance.
- f. If the Feet Spread does not read the correct distance, press Next until you reach the Calibration Page.
- g. Press Select until the F-Cal is highlighted. Press Edit and at this point a pop-up window should display Feet Spread.
- h. Use the Up and Down buttons to make the pop up window read the correct distance.
- i. Press OK to save and exit.

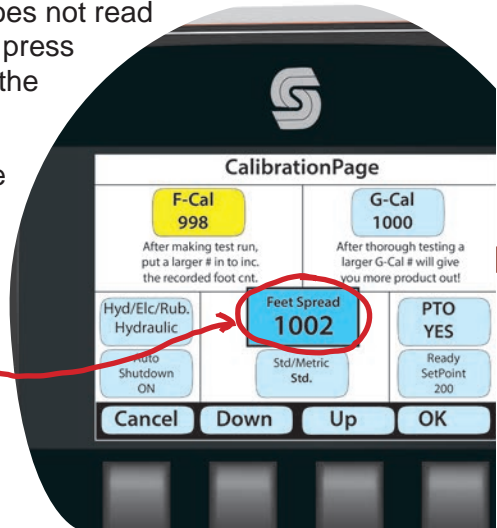

Display

### G-Cal

(Gallons Calibration) used to calibrate the pump for compensation in pump wear or variables in material viscosity . The pump is used as a meter to control the amount of material applied. Each revolution of the pump delivers a calculated amount of product. Because this amount can change over the life of the pump or a drastic change in viscosity of the material, the G-Cal can be adjusted to suit. The most common cause of a light spread rate is plugged or dirty screens. Always check and clean screens prior to adjustment. If the pump is worn, it may begin to slip or leak internally resulting in a light spread rate. High viscosity materials can have a similar effect so remember that viscosity in asphalt can

## 2013

increase or get thicker when it gets colder. It is a bad idea to change the G-Cal to compensate for equipment neglect (plugged screens) or poor material handling (letting asphalt get cold). It is an even worse idea to make G-Cal adjustments on short shots (1000 gallons or less). Start compensating by increasing or decreasing the spread rate (GSY Inc/Dec). If a change in spread has no effect then screens are plugged or you are over speeding the pump (driving to fast). If an increase or decrease in spread rate solves the problem, your G-Cal needs adjustment.

You have increased or decreased your spread rate and the output is correct. Prior to the next shot you remembered to zero the gallons used on the home page and take note of the position or level on the tank gauge. You spread a measured distance by a continuous width and the gallons used on the home page is wrong but the outside tank gauge reads correctly.

- Do not make any changes on the Home Page.
- Press Next to scroll to the Calibration Page.
- Press Select to highlight G-Cal.
- Press Edit and a pop-up window will display Gallons Used.
- Use the Up/Down buttons to change the Gallons Used window to match the actual gallons used on the outside Tank Gauge.
- Press OK to save and exit.
- Press Next or Back to return to the Home Page and adjust the Spread Rate to the desired amount.





Making G-Cal adjustments on longer shots will have a more accurate effect. Also calculating spread rate on longer shots is more accurate. There are a lot of variables when calculating spread rate and the most important one is determining gallons used on the Tank Gauge. The gauge can be effected by the location in which you are parked. If accurate readings are required, you must find a common level location to take readings. Average your spread rate calculations over at least three shots. Do not make a G-Cal adjustment on every shot. Use the GSY Inc/Dec to correct the shot, test over a few shots without any changes, make a G-Cal adjustment and you will achieve an accurate G-Cal.

### Hyd/Elc/Rub

A Factory setting for the type of system installed on the truck. Hyd (Hydraulic) is the standard hydrostaic controled and driven asphalt pump. Elc (Electric) is the 48v electricly controled and driven asphalt pump. Rub (Rubberized) is a unique stystem setting for the 960 pump. The 960 is not internally pressure relieved and requires different external plumbing and valving to provide pressure relief.

### Auto Shut Down

The Display will power down after 120 minutes of idle time. This setting turns this feature on or off.

### Pump Size

A factory setting for the asphalt pump installed. Select and press edit to change pumps by pressing up or down, then press OK to save and exit.

### Std/Metric

(Standard or Metric) changes all the values from standard or (english) to metric. Select and press On/Off to switch.

### PTO

If the truck is equipped with a standard or transmission PTO (must be engaged manually), this enables the controls for the switch and valves and should be set to YES. If your truck has a crankshaft, REPTO, or an external engine PTO then this option should be set to NO. Select and press On/Off to toggle between YES and NO.

### Ready SetPoint

In normal operation with the Master switch OFF, the pump and spraybar is in circulate mode. When you start moving and turn on the Master switch, the pump has to go instantly from Idle or circulate speed to

# 2013

the correct speed based on your travel speed (FPM), spread width, and spread rate (GSY). Prior to turning on the Master switch, if Ready is selected by pressing the Master switch down, pump speed control changes from Idle or circulate speed to simulated spreading speed. This enables the pump to reach proper speed prior to starting so the spread rate is exact when turning On the Master switch. This can help minimizing flooding on light shots and streaking on heavy shots. The Ready SetPoint is simulated FPM or travel speed at start. To determine this setting, practice a couple of starts by backing up to the start line and pretending to start the shot. Watch the FPM on the Home screen and note the speed as you start moving when you would turn on the Master switch. Select Ready Set Point on the Calibration page and press Edit. Use the Up or Down buttons to change the setting to the noted speed and press OK to save and exit.





## Switch Diagnostic Page

Continuing to hit the Next button will eventually land you on the Switch Diagnostic Page. Represented on this page is a switch from every option available (there may be switches you don't have). The switch on the screen or display should act just like the mechanical switch on the Console. If you turn a switch on or off the switch on the display should mimic the same movement. This is for diagnostics only. If a problem arises with a switch or function, you can check the computer side of the electronics by testing the switch on this page. Switches on the Console are triggers or indicators for the computer to make functions operate. They are not actually switching voltage to control the function. They only switch signal voltage to the node or computer. If there is a problem and the switch is working on the diagnostic page, then the problem is not the switch.



Display

## SPRAYING COMPLEX PATTERNS

Any number of patterns or shapes can be sprayed quickly and accurately, using a minimum of handwork, when the Model BC502/CRC distributor is employed properly. Two ingredients are essential for the successful completion of a complex spray operation:

The operator must be thoroughly familiar with the Model BC502/CRC operating controls.

The moves required to complete a spraying operation must be planned in advance. No move should be undertaken until the next one is known.

The following examples of pattern spray operations show typical ways in which the equipment can be employed. Many other approaches are possible. However, no operation should be commenced until both of the conditions listed above have been satisfied.



### Parking Lot

Plan of a parking area with restricted entrance and exit routes. Concrete curbing bound perimeter. The entire surface within curbed area is to be sprayed. (Entrance and exit routes were previously completed to the dashed lines shown in the drawing.) It is important to plan the operation so there will be no need to drive the distributor truck across a sprayed area.

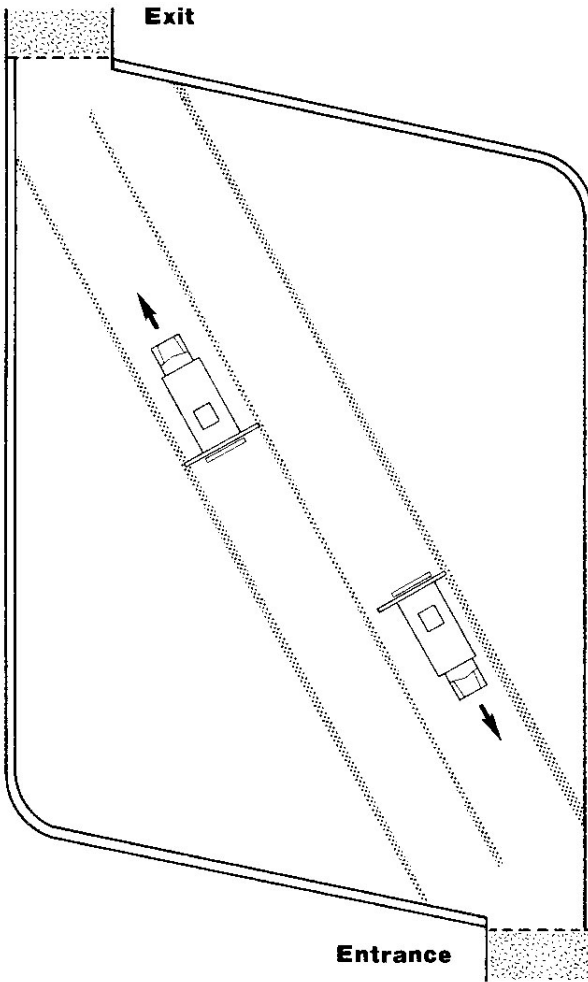

Step 1. To outline a central clear area, the truck is first driven diagonally across the parking area in two passes: first with both marker valves open, and again with only the left hand marker valve open. The result is a defined area of twice the width of the spray bar.

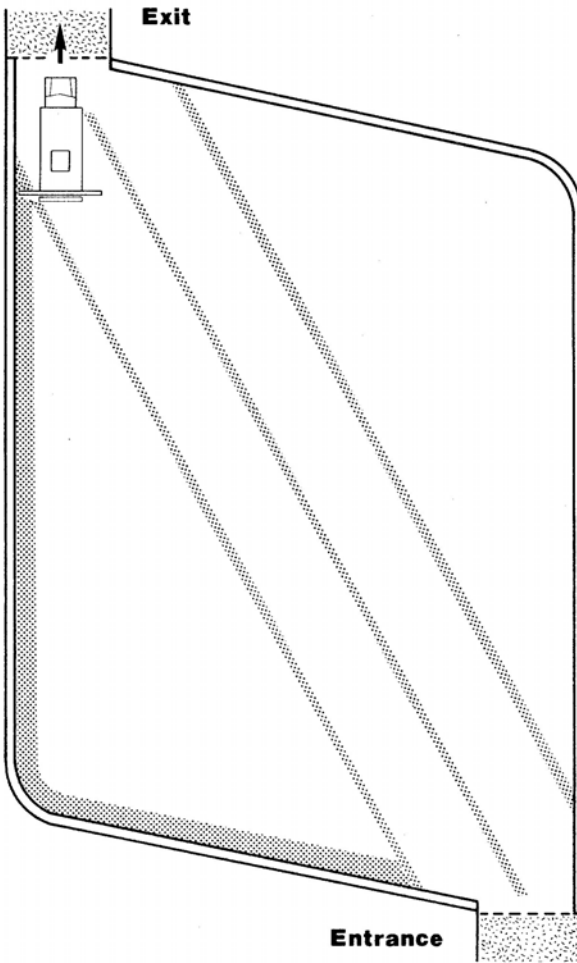

Step 2. The truck is driven around the left hand portion of the curbed perimeter with only the left wing spray valves open. The spaces at the entrance and exit are left unsprayed.

NOTE: More satisfactory lines with the line markers may be obtained by turning the pump off.

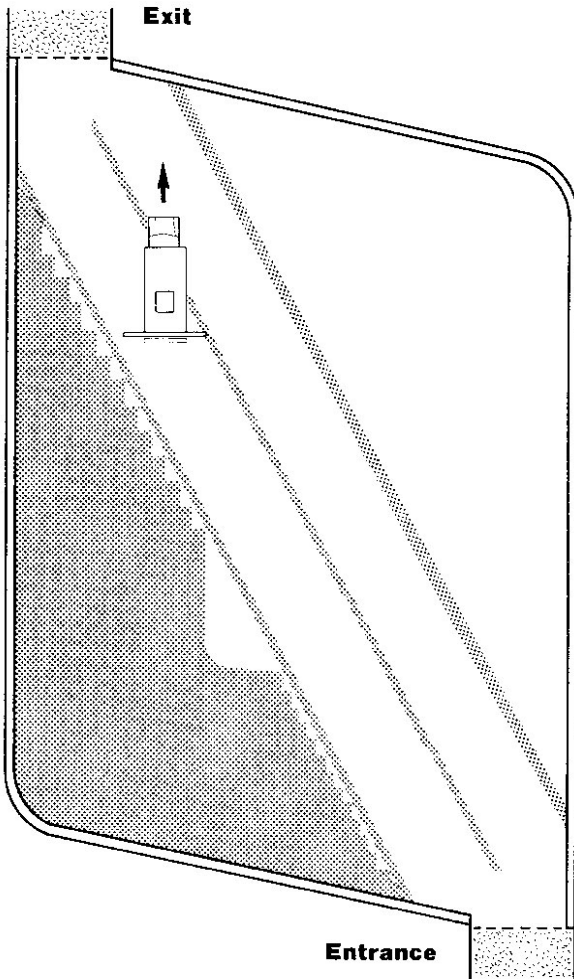

Step 3. The truck is positioned parallel to the left hand curb at the entrance area. As the vehicle is moved forward, spray valve switches are turned on to produce the pattern shown. When the farther section of the area is reached, the switches are turned off in the appropriate sequence.

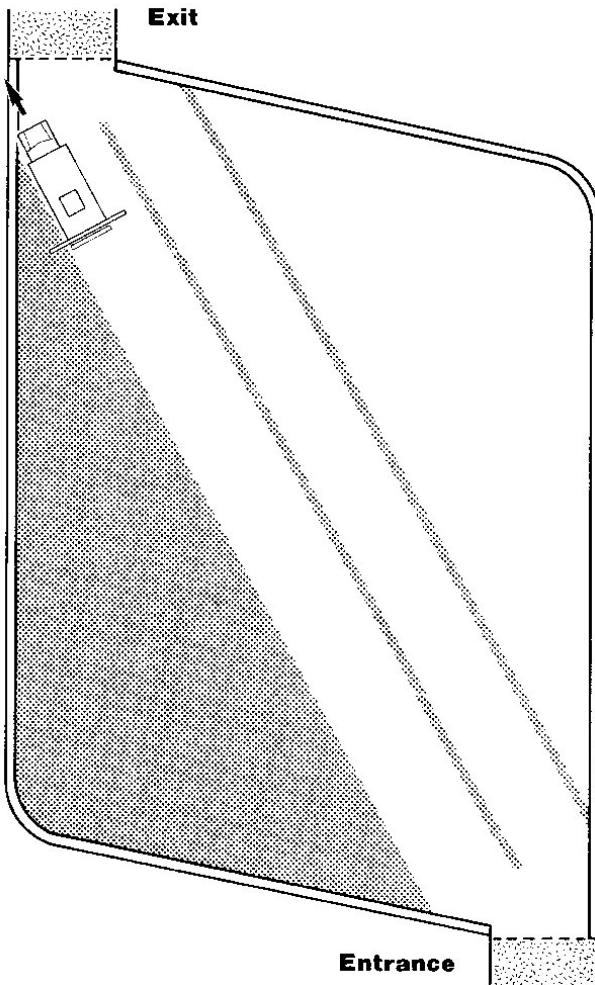

Step 4. The truck is driven along the central clear area with one wing projecting over the edge of the area sprayed on in Step 5. The wing spray valves are switched on and off as needed to produce the pattern shown. The result is a straight edge along the clear area.

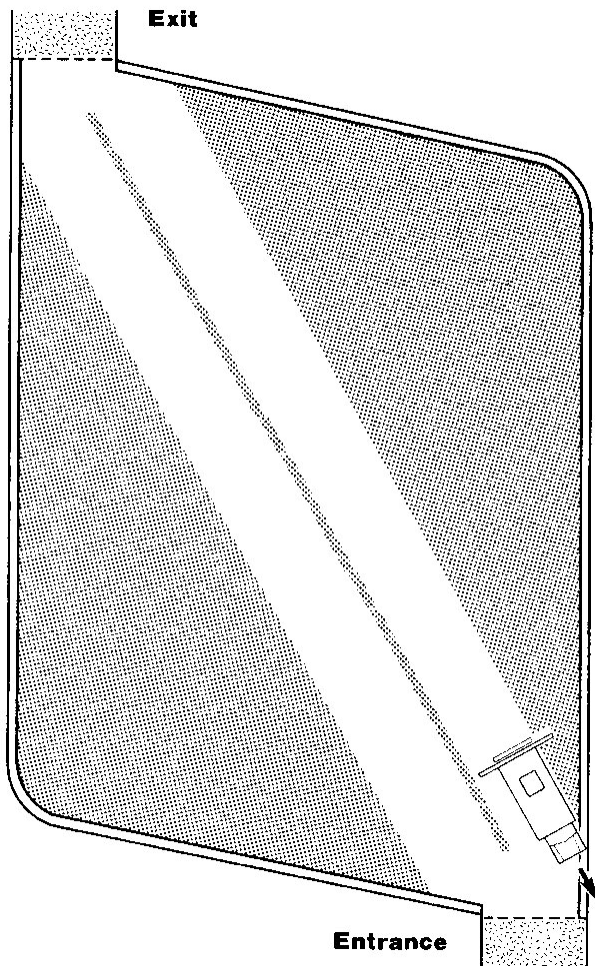

Step 5. Steps 2 through 4 are repeated on the right hand side of the area to produce the pattern shown.

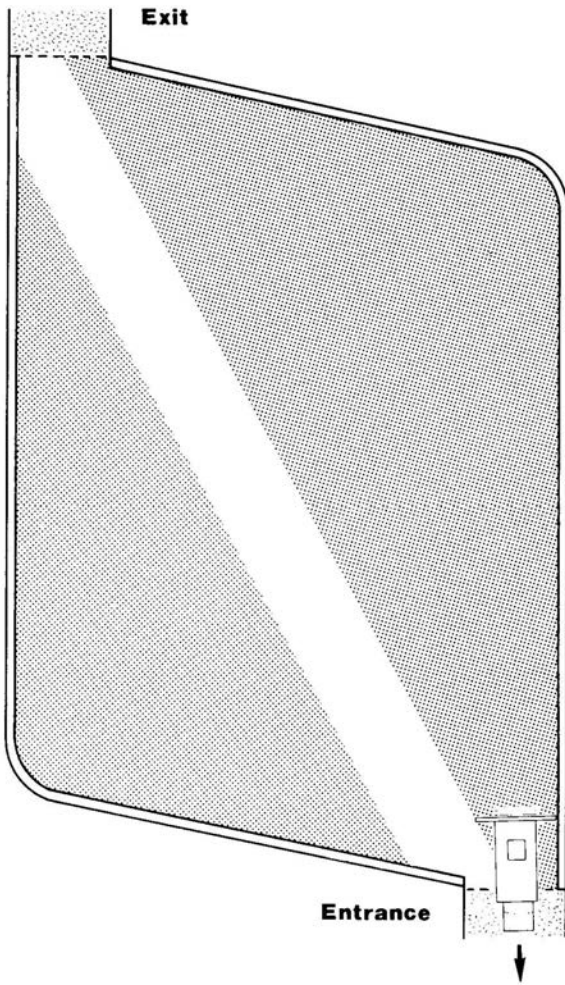

Step 6. The right half of the central clear area is sprayed in one pass from the exit end. Recall that the clear area was made twice the full width of the spray bar.

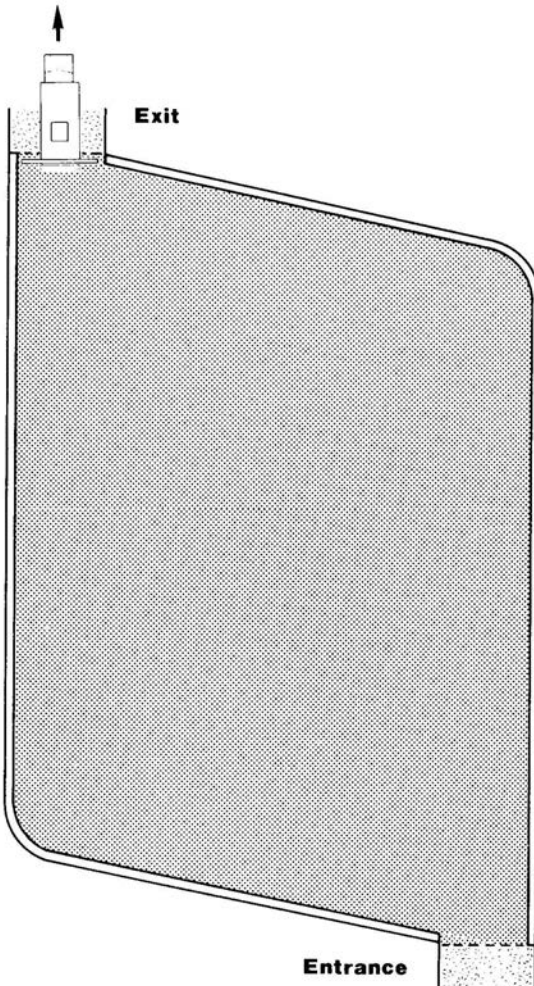

Step 7. Finally, the remaining half of the central area is sprayed in a single pass from the entrance to the exit. The entire area can now be spread with chips.

T - Intersection

T - intersection at which the job requirement is to coat the secondary road up to the line where it joins the primary. The chip spreader is instructed to stop at the dashed line and hold there until the intersection has been sprayed.

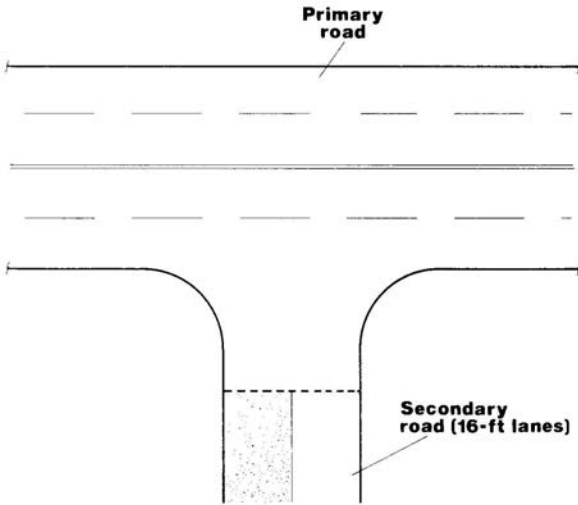

Step 1. To define the work area, the truck is driven from A to B with a marker valve open, then from C to D and from E to F to produce the guidelines shown.

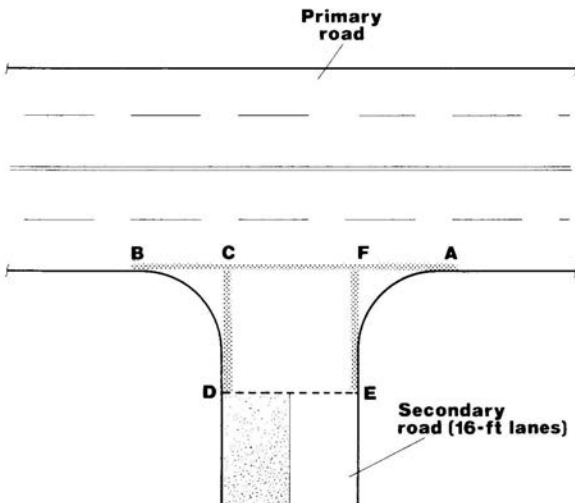



Step 2. The left hand and right hand corner areas are sprayed. As the truck is driven through the arcs, spray valve switches are turned on and off as needed to produce the patterns shown.

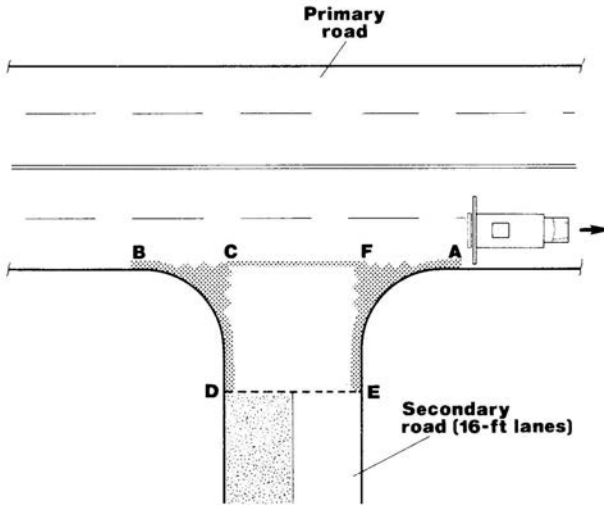

Step 3. The irregular edges along the lines BC and FA are sprayed. The truck is driven along the primary road with only as many wing spray valves open as are needed to make a smooth edge.

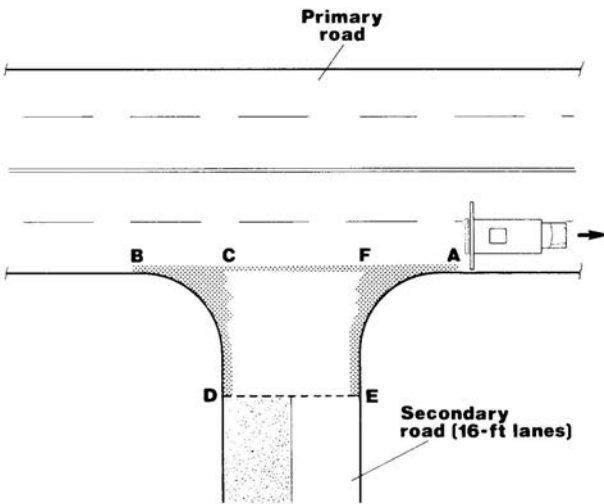

## 2013

Step 4. The truck is backed into position to spray the left hand portion of the secondary road, starting at the dashed line that marks the termination of the previous work. (If any hand spraying along the line DC is required, it should be completed first.)

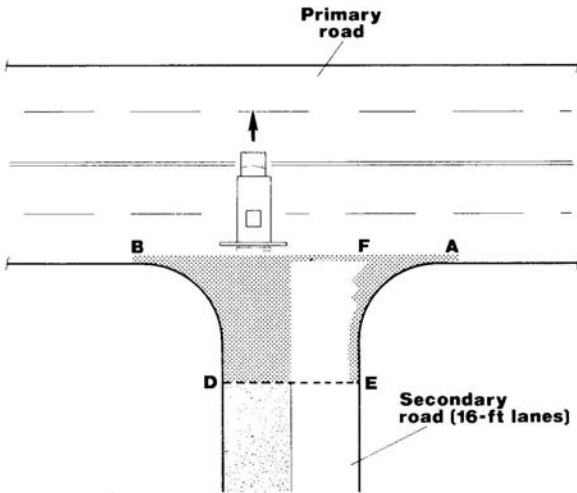

Step 5. Last, the right hand section of the road is sprayed (after any necessary hand spraying). At the conclusion of the spray run, the truck is located as shown. The entire intersection can now be spread with chips.

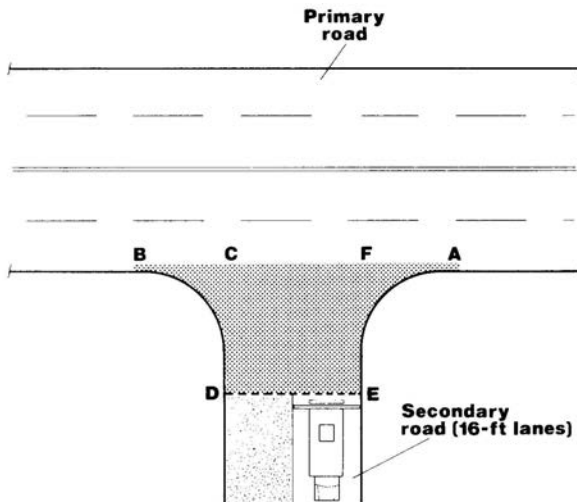



## Recommended Operating Practices

This Section contains procedures that have been developed through experience with asphalt distributors under a wide variety of working conditions. Users of BearCat asphalt distributors will find these procedures helpful and timesaving. BearCat users who develop techniques to improve the efficiency of the spreading operation are encouraged to report these techniques. The information will be passed along to other holders of this Operating Manual.

### Using a Guide Chain

A chain can be hung from the guardrail that runs along the top of the spray bar. It should be located at the outer limit of the spray pattern and positioned so that the end of the chain just touches the ground when the spray bar is at working height. The chain will be visible from the cab, showing the exact location of the spray nozzles relative to the surface and help to avoid overlaps and gaps.

### Shooting a Straight Line

The following techniques will be helpful in controlling the vehicle so the sprayed area follows a straight line with minimum need for weaving, jogging, and random corrections.

When following an existing continuous line, such as a curb or guide string, use the side shift as little as possible. Steering the vehicle to the guideline will yield a smoother result.

When following a line of stakes or markers, DO NOT attempt to guide the vehicle from stake to stake. You may create a scalloped effect. Instead, choose a reference point (power pole, building, tree, etc.) in line with your direction of travel and as far away as possible. Steer toward the reference point. As the spray bar passes each stake, watch it in the mirror and make minor corrections with the SWING switch.

Always make steering corrections as gradually as possible. Avoid sharp jogs. They will be even more visible from ground level than they are from the cab.

When backing the vehicle to connect with an area that has already been sprayed, it is common for the truck to be at a slight angle relative to the line of the existing spray. To continue the required pattern, the operator must make a steering correction immediately when beginning the new

## 2013

spray run.

To avoid the appearance of a jog in the spray pattern under these conditions, use the following technique:

Set the spray bar in the center of its travel (SWING).

Drive to a point far enough away from the connection so that you have adequate space to back straight toward the connection.

For approximately the final 50 feet of the backing run, grip the steering wheel firmly with your left hand and place your left arm solidly on the window frame. The object is to prevent the steering wheel from moving. In this way, you can make sure that the truck will arrive at the connection point with the wheels straight.

At the connection point, the spray bar may be transversely offset from the existing pattern. Use the SWING switch to make the needed correction.



## FIELD MAINTENANCE

Overall productivity of the asphalt distributor can be increased and equipment downtime minimized by carefully following the procedures given in this Section. Regular flushing of the spray bar is especially important to avoid the time consuming process of clearing a bar plugged with frozen asphalt.

### Flush the Spray Bar

**CAUTION: TO PREVENT SPRAY BAR VALVES FROM FREEZING, THE SPRAY BAR MUST BE FLUSHED WITH DIESEL FUEL AFTER EACH WORK SHIFT.**

If the spray bar is not flushed after each work shift, residual asphalt could build up and solidify in the spray bar. The residual asphalt could freeze the valves in the spray bar and create a time consuming effort to free them. Procedure for flushing Spraybar as described in Chapter 4 Spray bar Flushing.

### Clear Spray Bar Clogged with Frozen Asphalt

Preferred Method: Clearing with Live Steam

**CAUTION: IF A WRENCH IS NECESSARY TO OPEN THE SPRAY VALVE, APPLY AS GENTLE A FORCE AS POSSIBLE TO AVOID DAMAGE TO THE VALVE LINKAGE.**

- a. Manually open the first set of spray valves at either end of the bar. Use a wrench if necessary but apply force as gently as possible to avoid damaging the valve linkage.
- b. Connect the steam supply to the outermost spray nozzle.
- c. Allow steam to enter the bar until asphalt flows from the two exposed nozzles (normally about 15 minutes).
- d. When the nozzles are clear of asphalt, close the valves and open the next set of three. Wait for them to clear.
- e. Repeat Steps A through D across the full length of the

spray bar.

- f. If a supply of steam is not available, use the following procedure instead.

### Alternate Method: Clearing with a Torch

---

**WARNING: CLEARING A SPRAY BAR WITH A TORCH CREATES A POTENTIAL FIRE HAZARD. TO AVOID SEVERE BURNS, INJURY OR DEATH DO NOT BEGIN THIS PROCEDURE WITHOUT A DRY CHEMICAL FIRE EXTINGUISHER AVAILABLE. MAKE SURE THAT THE TORCH FLAME IS KEPT WELL AWAY FROM ALL HOSES AND AIR CYLINDERS.**

---

- a. Manually open all of the spray valves on the bar. Use a wrench if necessary but apply force as gently as possible to avoid damaging the valve linkage.
- b. Apply heat with the torch to the underside of the spray bar, moving the torch back and forth until asphalt flows from the spray nozzles. **BE SURE TO KEEP THE FLAME WELL AWAY FROM HOSES AND AIR CYLINDERS.**
- c. Continue heating the bar until asphalt flows from the nozzles and then stops, indicating that the bar has been cleared of all material.

### Clear Clogged Spray Nozzle

If asphalt does not flow from a single nozzle, the blockage is in the nozzle. Remove it with a wrench and clear the obstruction by pushing a wire through the nozzle. If asphalt continues to flow when the valve is commanded to close, the blockage is in the valve seat area. Run the pump in REVERSE to remove material from the valve.

---

**WARNING: THE PUMP MUST BE IN REVERSE WHEN REMOVING THE NOZZLE VALVE BUSHING. FAILURE TO PUT THE PUMP IN REVERSE COULD RESULT IN SEVERE BURNS, INJURY OR DEATH.**

---

If running the pump in reverse does not clear the obstruction and restore the valve to proper functioning, the nozzle valve bushing must be removed, and the valve must be cleared manually.



## Clean Asphalt Intake Strainer

The intake strainer is located behind Valve A. Clean it daily or as needed. The easiest time to clean the strainer is just after flushing the spray bar.

- a. Be sure pump is turned off.
- b. Ensure valves C and B are closed.
- c. Remove the four nuts at the corners of the cover plate immediately behind Valve A.
- d. Remove the four lugs and take off Valve A.
- e. Pull out the cylindrical screen and remove the material collected on it.
- f. Inspect the flexible gasket on the cover plate. Replace it if any damage is visible.
- g. Replace the screen, valve, lugs, and nuts.
- h. Tighten the nuts evenly.

## Clean Bar Screen

Clean the spray bar screen daily or as needed. The screen is located inside the Y chamber immediately behind the hand spray hose reel.

- a. Be certain pump is turned off.
- b. Remove the four nuts that hold the cover plate.
- c. Take off the plate and remove the internal gasket.
- d. Pull out the cylindrical screen and remove the material collected on it.
- e. When reinserting the screen, be sure it is properly seated in the locator ring inside the Y chamber. You may need to rotate the screen until it fully enters the chamber and seats in the locator ring.
- f. Replace the cover plate. Tighten the nuts evenly.

## Replace Swing Joint Seal

Carry out the following procedure if leakage develops at the wing swing joint. There is no adjustment for leaking seals. They must be replaced.

### Disassembly

- a. Lower the wing to the horizontal position.
- b. Remove the 2inch pipe plug at the bottom of the swing joint.
- c. Clean out any asphalt debris from the opening and remove the two locking nuts from the shaft.
- d. Remove the two washers from the shaft.
- e. Pull the wing assembly out of the swing joint sleeve.
- f. Pry the seal out with a screwdriver. Push it away from you until it is clear of the seat; then remove it through the plug opening.

### Seal Replacement

- a. Warm up new seal. They are more flexible, and will not kink as easily
- b. Wipe the seat clean and apply a thin coating of grease.
- c. Hold the new seal in your fingers and position it so that the lips of the seal are pointing away from you. Very gently bend the seal into an oval or egg shape only as much as necessary to slip it past the seat area.
- d. When the seal is past the seat area, gently work one end of the oval into the seat. Then move your fingertips around the seal, a little at a time, until it is seated. **BE CAREFUL** at all times not to force the seal or bend it excessively. If a kink develops, the seal will no longer be usable.

### Reassemble

- a. Wipe the shank of the wing clean and apply a thin coating of grease.
- b. Replace the wing assembly. Maneuver it into the swing joint sleeve until it is fully seated.



- c. Replace the two washers.
- d. Replace the two locking nuts. Snugtighten the first nut; then lock the second nut to the first nut.
- e. Replace the 2inch pipe plug.

## Replace Asphalt Pump Seals

In pumps equipped with the optional lowmaintenance shaft seals, two seals are located where the pump shaft connects to the drive shaft from the hydrostatic motor. These seals should be replaced if leakage appears. Replacement seals are available from BearCat Mfg., Inc.

- a. Unbolt the companion flanges from the pump and detach the drive shaft.
- b. Remove the key from the pump shaft. It can be pried out by using a punch and hammer.
- c. Remove three Allenhead cap screws and take off the seal retainer.
- d. Remove both seals and discard them.
- e. Apply a thin coating of Lubriplate No. 105 or equivalent grease to the new seals.
- f. Use emery cloth or fine sandpaper to smooth the pump shaft so there are no burrs or rough spots.
- g. Insert the larger asphalt seal into the pump.
- h. Install a new dust seal in the retainer with the seal lips facing outward.
- i. Replace the seal retainer, with the seal facing outward, and tighten the cap screws securely. This will seat the inner seal.
- j. Replace the shaft key, drive shaft, and companion flange. Tighten the bolts securely.

### Replace Nozzle Valve Stem Seals

The spray nozzle valves are equipped with seals and Orings that require replacement if leaks develop.

- a. Close Valve E and drain the spray bar.
- b. Use an 11/16" wrench to remove the seat bushing of the leaking valve. The bushing is located on the underside of the spray bar.
- c. Remove the locking nut from the top of the valve. Take off the lifting finger and put it aside.
- d. Push the valve stem assembly down through the seat hole and put it aside.
- e. Remove the snap ring from the valve hole. Use snap ring pliers only. Then remove the washer.
- f. Remove the O-ring and the seal and discard them.
- g. For this and the following steps, use the two piece seating tool (available from BearCat; P/N MSC-27280 and MSC-27281). Place the shorter seating tool in the valve seat on top of the spray bar. Put a few drops of light oil around the inner surface of the tool. This component of the tool may require grinding to enable it to clear the edge of the square tube valve lifter.
- h. Place the new seal on the longer tool. With the seal lips toward the spray bar, push the tool down inside the shorter tool until the seal is seated.
- i. Pull out both tool components.
- j. Install the new Oring on top of the seal.
- k. Replace the washer on top of the Oring.
- l. Replace the snap ring. **MAKE SURE** the ring is firmly snapped into the groove.
- m. Coat the valve stem assembly with light oil and reinstall it through the hole in the bottom of the spray bar.



- n. Replace the lifting finger.
- o. Align a flat side of the locking nut parallel with the edge of the square tube valve lifter and tighten the locking nut.
- p. Clean the seat bushing and washer and o-ring. Coat the threads with No. 1 Permatex gasket cement.
- q. Reinstall the seat bushing. Tighten it to 15 ft lbs. of torque. Avoid distorting the seat.

NOTE: Do not guess at the proper torque! Use a torque wrench.

## Adjust Actuators for Spray Nozzle Valves

This adjustment is set at the factory. It should not be changed in the field unless a linkage has been damaged so that the affected valves do not close properly.

- a. Inspect the valve assemblies and make sure they are clean and free of obstructions between seat and ball.
- b. Make sure the switch controlling the affected valve is OFF. Inspect the pneumatic cylinder and verify that the actuator rod is fully extended (approximately 1 inch).
- c. Examine the center valve of the affected set. The valve stem should show 1/16 in. remaining travel when pushed down. Use a dial indicator to measure the distance if one is available.
- d. If valve stem travel is more or less than 1/16 in., heat the control lever (connected to pneumatic cylinder actuator rod) with a torch and bend it until the proper travel is established.
- e. When the center valve has been properly positioned check the two remaining valves of the set. If adjustment is necessary to achieve 1/16 in. travel, twist the shaft as required.
- f. When all three valves have been properly positioned, measure the clearance between the edge of the square

tube and the flat of the nut that secures the valve stem. It must be at least 1/16 in. or the valve may become cocked.

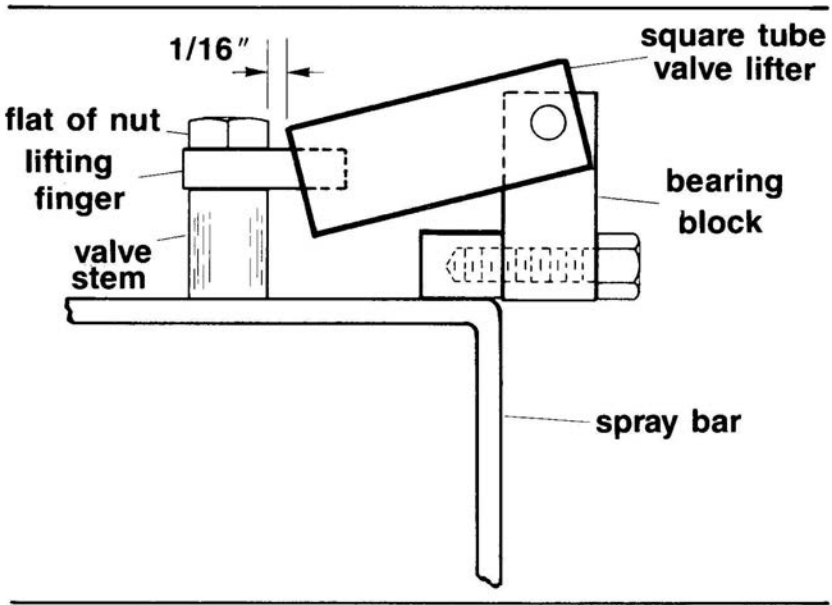

### Adjust Remote Curbside Mirror

The adjustable stops that position the mirror are located as follows:

UP: Upper of two adjustable bolts located on support bracket fastened to back of mirror.

DOWN: Lower of two adjustable bolts located on support bracket fastened to back of mirror.

IN: Adjustment bolts located in upper and lower mounting brackets where they join truck mounted support frame.

OUT: Adjustable bolt located on mirror back surface.





## Lubrication

Lubricate the distributor as listed below, at the intervals specified.

- a. Asphalt pump (certain models only):  
If the pump contains a fitting, lubricate weekly with chassis grease.
- b. Heating system air blower:  
Follow manufacturer's instructions included in this Operations Manual.
- c. Vehicle engine, drive train, running gear, etc.:  
Follow maintenance instructions provided by vehicle manufacturer.

## Preparation for Storage

To prepare the asphalt distributor for storage, as for a seasonal shutdown, proceed as follows:

- a. Purge any moisture that may be in the spray bar after distributing emulsified asphalt. Circulate approximately 20 gallons of diesel fuel or used engine oil in the system and allow it to remain in the spray bar.
- b. Close all asphalt valves and tank openings.
- c. Close off the tank vent located in the dome well to prevent moisture condensation. Use a plastic bag secured over the top of the vent with a rubber band.

## Removal of Spray Bar

If the spreader assembly must be removed to free the vehicle for other uses, consult the BearCat Mfg. Service Department (telephone (928) 684-7851) before proceeding.

## Hydraulic System Maintenance

The hydraulic system must be serviced at the beginning of each working season.

## 2013

- a. Drain the system through the drain plug located in the bottom of the hydraulic tank.
- b. Remove the spin-on filters adjacent to the hydraulic tank and discard them.
- c. Install new filters. Hand tighten only. Use the filters in our parts list.
- d. Close the drain valve and refill the reservoir with 22 gallons of Type 46 Hydraulic Fluid.
- e. Condensation that may build up in the hydraulic system is capable of clogging the filter. This condition can lead to insufficient hydraulic fluid at the pump, which will degrade the performance of the hydrostatic transmission and other components. To monitor the condition of the filter, periodically observe the vacuum gauge mounted on the filter housing. The gauge should not indicate higher than 10 inches Hg when the system is operating. If a higher vacuum is shown, the filter is obstructed and must be replaced.





## Cargo Pump Operation

The direction of rotation of the gears determines which port will function as inlet and which is outlet. Recall the rule of cargo pump operation:

FWD = IN at bottom, OUT at top

REV = IN at top, OUT at bottom

The cargo pump operates on the positive displacement principal. That is, when the gears un-mesh, a partial vacuum is produced. Atmospheric pressure can then force the bituminous material into the pump, where it is carried between the gear teeth and the casing to the other port. The meshing of the gears then forces the material through the outlet port.

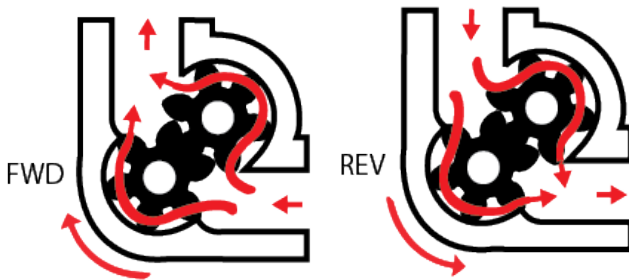

Note the maximum acceptable clearance between gear teeth and casing is 0.015 in.

**CAUTION:** THE CALIBRATION, ADJUSTMENTS, AND DEFAULT VALUES WILL AFFECT OPTIMUM OPERATION OF THE EQUIPMENT. THESE VALUES ARE SET BY THE MANUFACTURER AND SHOULD NEVER REQUIRE MODIFICATION. IF SYSTEM PERFORMANCE INDICATES THAT CALIBRATION IS NECESSARY, CONTACT THE BEAR-CAT SERVICE DEPARTMENT BEFORE PROCEEDING WITH ANY CALIBRATION OR ADJUSTMENT.

To change the calibration and default values, proceed as follows:

- f. On the Console Display press “next” until you reach the Calibration Page.
- g. Press “select” until the desired “G-Cal” or “F-Cal” box illuminates yellow.
- h. Press “edit”.
- i. Press up or down to change the setting.
- j. Press “OK”.

FCAL footage calibration. A setting of + 1 raises the measured footage by 1 part in 1000. A setting of 2 lowers the measured footage by 2 parts in 1000, etc.

GCAL Pump calibration (Gallons Calibration); raises or lowers measured pump rate by a factor of GCAL/ 1000 (like FCAL).



Calibration Page



## Equalizer Valve Packing

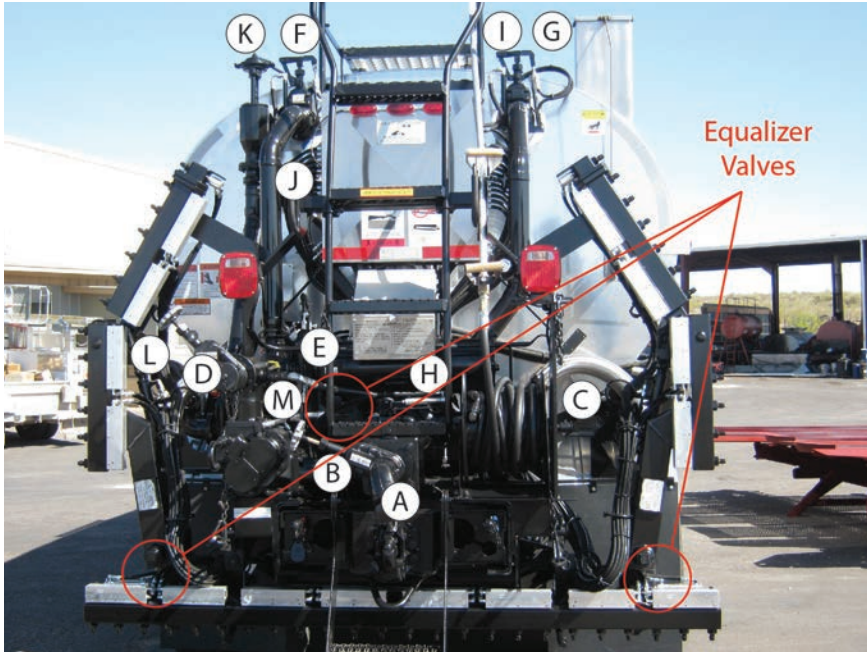

The three equalizer valves shown require periodic tightening of packing nut. Under the packing nut is graphite rope packing that seals the valve shaft. Over tightening of the packing nut can seize the shaft and prevent movement. If a leak cannot be stopped it is time for new shaft packing. Remove the packing nut, clear out old graphite rope packing and replace with new. The “K” valve also has similar packing.

### K Valve (spread circulate) or “bypass valve”

When the Master switch is turned on, a pneumatic valve in the rear control box supplies air through a pre-set 60 psi regulator to a diaphragm cylinder which presses down on a disk to close the spread circulate line. Sometimes a piece of coke or hard contaminate can stick to the seat of the disk. This can cause bypass or leakage through the “K” valve resulting in light spread rate or the loss of an entire tank of flush fluid. The disk can be checked and cleaned without the removal of the “K” valve.

a.

## 2013

- a. (Product pump in neutral) remove 6 bolts on top of "K" valve. (Be careful with gasket) Lift the top of the assembly out of the valve housing. Notice the slots in the top outside the large hole. If they are not visible, the gasket has stuck to the bottom instead of the top as shown in picture.
- b. With a piece of wire or screwdriver, lift out disk.



- c. Clean and inspect the disk seat. The surface should be smooth and clear of debris. Also inspect the the valve seat inside for similar problems. Some emulsions and corrosive products can cause pitting which will result in valve replacement.
- d. Inspect the O-ring that seats on the top of the disk.
- e. Reassemble the valve by inserting the disk back into the valve housing (seat facing down).
- f. Replace gasket and check to see that O-ring stays in place while reassembling top.





SYMPTOM	POSSIBLE CAUSE	SOLUTION
Does not achieve proper spread rate.	<ol style="list-style-type: none"><li>1. Clogged filter screens.</li><li>2. Malfunction in equalizer valve.</li><li>3. Malfunction in asphalt pump relief valve (valve opens at less than correct pressure or valve action is blocked by obstruction).</li><li>4. Excessive wear in asphalt pump.</li><li>5. Obstruction in tank restricting flow of asphalt through tank valve.</li><li>6. Recirculate valve (F) leaking.</li><li>7. Spread/Circulate “K” valve leaks.</li></ol>	<ol style="list-style-type: none"><li>1. Clean per instruction in this section.</li><li>2. Examine valve action to verify that valve opens when Master Switch is on, closes when switch is off. Repair valve or actuator as needed.</li><li>3. Verify valve action; repair or replace as needed.</li><li>4. Inspect pump and replace parts as needed.</li><li>5. Clean tank to remove obstruction.</li><li>6. Be sure it is closed tight. Replace if needed.</li><li>7. Clean seat. Check air pressure. Should be 40 to 60 psi with master switch on.</li></ol>
Asphalt pump develops excessive noise. Insufficient flow of asphalt due to clogged filter screen or blocked intake valve. Inspect filter screens and valves and clean as required.		
Hydrostatic pump develops excessive noise.	Insufficient fluid available due to clogged filter or plugged line.	Replace filters and inspect lines.
Asphalt does not circulate through spray bar.	<ol style="list-style-type: none"><li>1. Master switch on.</li><li>2. Malfunction in equalizer valve.</li><li>3. Bar clogged with hardened asphalt.</li></ol>	<ol style="list-style-type: none"><li>1. Set switch off.</li><li>2. Examine valve action to verify that valve opens when Master Switch is on, closes when switch is off. Replace valve or actuator as needed.</li><li>3. Clean bar by one of the methods given in this Section.</li></ol>
Spray bar fails to complete commanded motion (bar raise, bar shift, or wing lift).	<ol style="list-style-type: none"><li>1. Blockage in solenoid-operated hydraulic valve.</li><li>2. Lack of signal from control panel.</li></ol>	<ol style="list-style-type: none"><li>1. Actuate valve manually by pressing plunger at each end of valve with a small screwdriver.</li><li>2. Check switches and wiring for continuity; replace as needed.</li></ol>

SYMPTOM	POSSIBLE CAUSE	SOLUTION
One set of spray nozzle valves does not operate	Malfunction in solenoid-operated air valve.	Replace with new solenoid-operated air valve.
Burner does not start.	<ol style="list-style-type: none"> <li>1. Is switch turned on?</li> <li>2. Is the truck brake set?</li> <li>3. Motor is locked up.</li> </ol>	<ol style="list-style-type: none"> <li>1. Turn switch on.</li> <li>2. Pull the yellow button. Check pressure switch in brake safety valve. Replace if necessary.</li> <li>3. Replace motor.</li> </ol>
Blower turns but burner does not ignite.	<ol style="list-style-type: none"> <li>1. No smoke from stacks.</li> <li>2. No oil flow at nozzle.</li> <li>3. System appears to be air bound.</li> <li>4. Blows white smoke.</li> </ol>	<ol style="list-style-type: none"> <li>1. Check fuel level. Check coupling in burner, replace if necessary.</li> <li>2. Clean Clogged screen in nozzle or replace nozzle.</li> <li>3. Check for and insert by-pass plug in return port on fuel pump.</li> <li>4. Check for proper voltage at coil. Replace if necessary. Check condition of electrodes and gap settings.</li> </ol>
Burner ignites but exhaust is black.	<ol style="list-style-type: none"> <li>1. Smoke from stack is black.</li> <li>2. Flame seems to be backing up into burner.</li> </ol>	<ol style="list-style-type: none"> <li>1. Remove burner and check for soot build up. Remove any build up that is found.</li> <li>2. Make sure stack lid is open.</li> <li>3. Check fuel pressure. Should be at 150 psi.</li> </ol>
Dual burner failure.	Second burner will not operate.	<ol style="list-style-type: none"> <li>1. Lower burner must be operating in order for the upper burner to operate.</li> <li>2. If upper burner still fails to operate follow the procedure for checking out a single burner.</li> </ol>

For additional help on burner trouble shooting watch the Diesel Burner Repair Video.

<http://www.bearcatmfg.com/Video/DieselBurnerRepair/DieselBurnerRepair.html>

If burner still fails to operate correctly contact BearCat's Service Department. 928-684-7851



**2013**



**2013**