

CRC TANDEM 8' to 16' Stealth Chipper



CRC Tandem 8' to 16'

Chip spreading widths from 1' to 16'

- **Low maintenance** Non-contacting ultra-sonic belt sensors, provide measurement of the chip pile height, for belt speed (on/off) control.



Tandem 8' - 16'

- 275HP Cummins QSB6.7L Tier3 6cyl. diesel.
- Tier 4 engine available
- Large engine & hydraulic cooling systems to insure normal operating temperature even on the tough jobs.
- Single operator station, swings left & right.
- Front wheel drive (Optional 4WD).
- State of the art Computer Rate Control (CRC).
- Parts commonality with 10' - 20' Tandem Chipper

CAM Position Cylinders

- Hydraulically driven position sensing cylinders.
- Non-contacting Hall-effect percent open sensor.
- Reliable and accurate control of the gate position CAM.

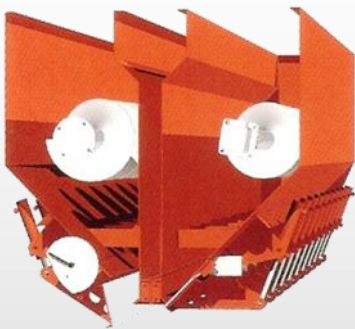

Spread Hopper

- HSLA steel construction tandem hoppers extend from 8' to 16'.
- A 14" abrasion resistant auger moves materials to the outside gates.
- No agitator or spread roll to wear or limit production.
- Oversized objects pass through the largest opening in the industry.
- The tandem design allows for straight line starts and minimal aggregate waste.





Proudly Made in Wickenburg, Arizona USA



CRC

- State of the art Computer Rate Control (CRC).
- Operator convenience & adjustable control positions designed into the chip spreader.
- Onboard Diagnostics

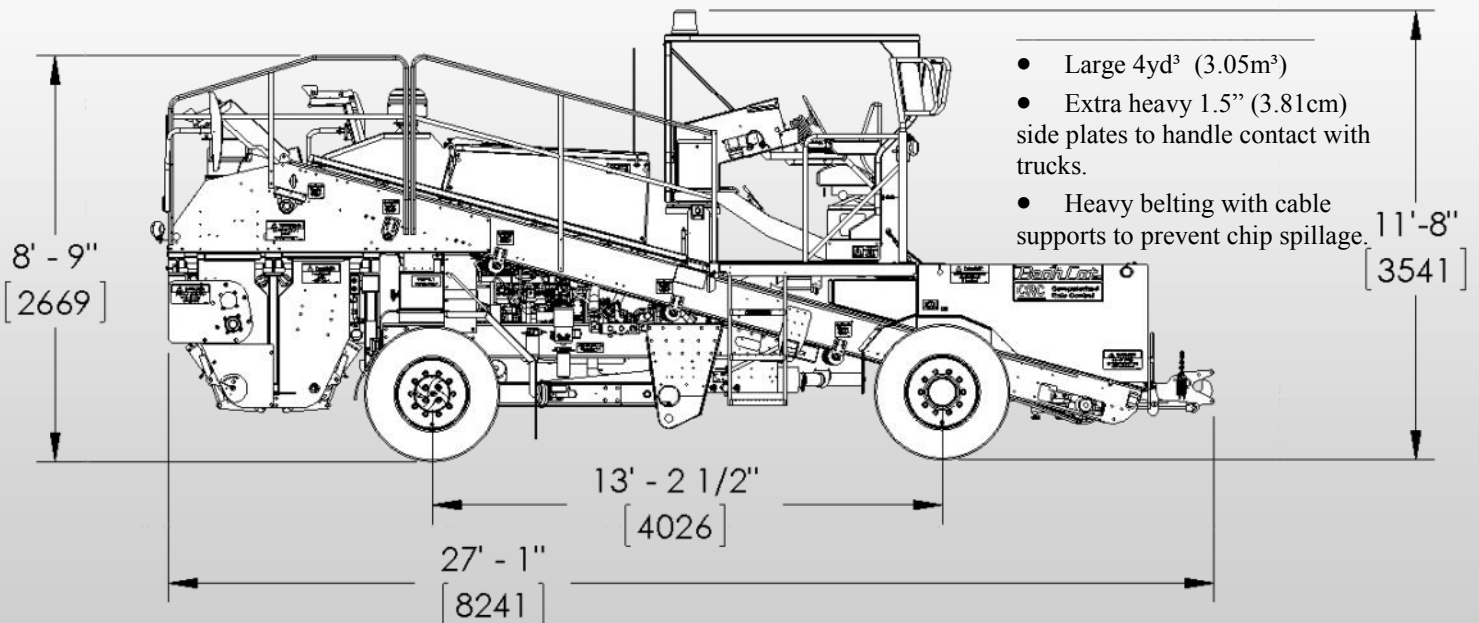

- Large 4yd³ (3.05m³)
- Extra heavy 1.5" (3.81cm) side plates to handle contact with trucks.
- Heavy belting with cable supports to prevent chip spillage.

Engine and Drive-train

- Cummins Tier3 QSB6.7L 6-cylinder Diesel. Tier 4 available.
- 275 HP @ 2,300 RPM.
- 730 ft-lb of torque @ 1,500 RPM.
- Air compressor; engine mounted Wabco 17 CFM @ 2400 RPM.
- Wabco System Saver 1200 series 12 VDC air dryer.
- Dry type air cleaner, disposable element type oil filter.
- Hydrostatic Transmission (6,000 psi / 410 Bar):
 - 130 cc variable displacement piston pump.
 - 160 cc variable displacement piston motor.
 - 2-speed (high/low) transfer-case (Electric / Air Shift).
 - Automotive control w/HP & Anti-stall control; drives like a truck with and automatic transmission.

Axles, brakes and tire

- Front Wheel Drive, 14.769:1 planetary drive/steer axle, 42 degree turn angle, 31,800 lb (14,425 kg) w/rubber suspension. Front axle integrated hydraulic steering cylinder.
- Steering system: Hydraulically powered orbital type, no mechanical linkage, with an engine mounted vane type power steering pump with a 6gpm flow control cover
- Solid tube type 5 in diameter trailer axle, 25,000 lb (11,340 kg) capacity, with oil filled wheel bearings.
- Optional: Four wheel drive. Uses a modified 23,000 lb truck axle and a BearCat differential mounted gear-box.
- Brakes, front: air over hydraulic:
 - Air over hydraulic master cylinder.
 - Service brakes; spring released, hydraulic applied, multi-disc wet disc pack.
 - Parking brakes; spring applied air-released disc, mounted on the front drive shaft.
- Brakes, rear:
 - Service brakes; 16.5 in x 7 in drum, S-cam air brakes.
 - Parking brakes; Spring anchor-lok.
- Tires: 385/165R X 22.5 highway tread
- Wheels: disc type 10 hole, front and rear are interchangeable.

Hydraulic system

- 130 cc pressure compensated axial piston pump, system pressure set at 2300 psi (160 bar)
- Hydraulic tank; 100 gallon (300 liter), closed to atmosphere 5 psi (0.35 bar) positive pressure system, to prevent moisture ingress.
- Large 53 in x 35 in (135 cm x 89 cm) oil cooler, with large 3 in (6.35 cm) plumbing with a large 24 in (61 cm) dia. temperature controlled hydraulic fan. One 15 gpm constant flow circulation filtering/cooling pump.
- Belt motors; 400cc LSHT, direct coupled to the head-pulleys.
- Auger motors; 624cc LSHT, direct coupled to the augers.

Dimensions

- Length: 27 ft (8.23 m) Width: 8 ft (2.45 m)
- Height: 12 ft (3.65 m) w/cab removed 9' 1" (2.75 m)
- Wheelbase: 13' 2 1/2" (4.03 m)
- Weight empty (shipping): 25,300lbs (11,475kg)

Material Handling Specifications

- Rear hopper is 8 ft (2.45 m) folded, 120 in (305 cm) wide fully open with a struck capacity of 4 cubic yards (3.05 cubic meters).
- Heavy 1 in (2.54 cm) side plates to handle contact with trucks.
- Belts; two heavy duty 20 in (76 cm), 2 ply conveyor belts with 35° troughing rollers.
- Belts speed (on/off) is controlled by ultrasonic position sensors measuring chip level in the chip spreading box.
- Spread hoppers; infinitely variable from 8 ft (2.45 m) to 16 ft (4.9 m), capacity 3.2 cubic yards (2.45 cubic meters) combined spread hopper total.
- Extensions; 1 ft (0.305 m) left & right available.
- Heavy duty spread gate CAM position cylinder w/non-contact position feedback sensor.
- Cut off gates: Pneumatic powered 12 in wide gate, with 1-1/2 in x 6 in (3.8 cm x 15.2 cm) air-cylinders.
- Hitch: Hydraulic positive non binding, latch and release.

Electrical system

- 12 VDC 160 amp belt drive alternator w/internal regulator.
 - Two 12 VDC Group 31-MHD / 950 cca batteries.
 - Computer Rate Control (CRC), Sauer-Danfoss Plus+1 CAN network communication, w/automotive style wire harnesses.
 - Operator display advanced color TFT 240 x 400 pixel, to display fuel level, hydraulic temperature, engine temperature, engine RPM, hour meter, charging system voltage and system diagnostics.
 - System diagnostics displayed on the color TFT display:
 - Battery voltage low/high, computer node communication okay, pictorial display of switch position, all sensor voltage or pulse (frequency) values, hydraulic & engine over-temp log, hydraulic oil level low log.
 - All electrical connectors, & controllers IP67 rated (pressure wash-down).
 - Any non IP67 rated connectors are crimped and soldered to prevent corrosion of terminals and copper wiring.
 - Field replaceable automotive style wiring harnesses.
 - Individual and tapper switch control of gate open and close.
 - Belt operation selection; OFF/Auto/Auto w/Master Switch ON.
 - Optional: High output low current draw light package.
- ## Single seat operator station
- The operator station hydraulically moves left/right and can be used on the left, right side or anywhere in between.
 - Dash panel is directly in front of the operator.
 - All chip spreading function control switches are on a control panel accessible while the operator's arm is on the right side arm rest.
 - Seat adjustments; fore & aft, backrest angle, and height.
 - Accelerator/Brake pedal adjustment; fore and aft.
 - Steering wheel adjustment; 30 deg of angle.
 - Operator station includes a rain/sun cover/roof.

BearCat Mfg.
 3650 Sabin Brown Road
 Wickenburg, AZ 85390
 Ph: 928-684-7851
 Fax: 928-684-5876
 www.bearcatmfg.com

