

ZONE		REV.	DESCRIPTION	DATE	APPROV

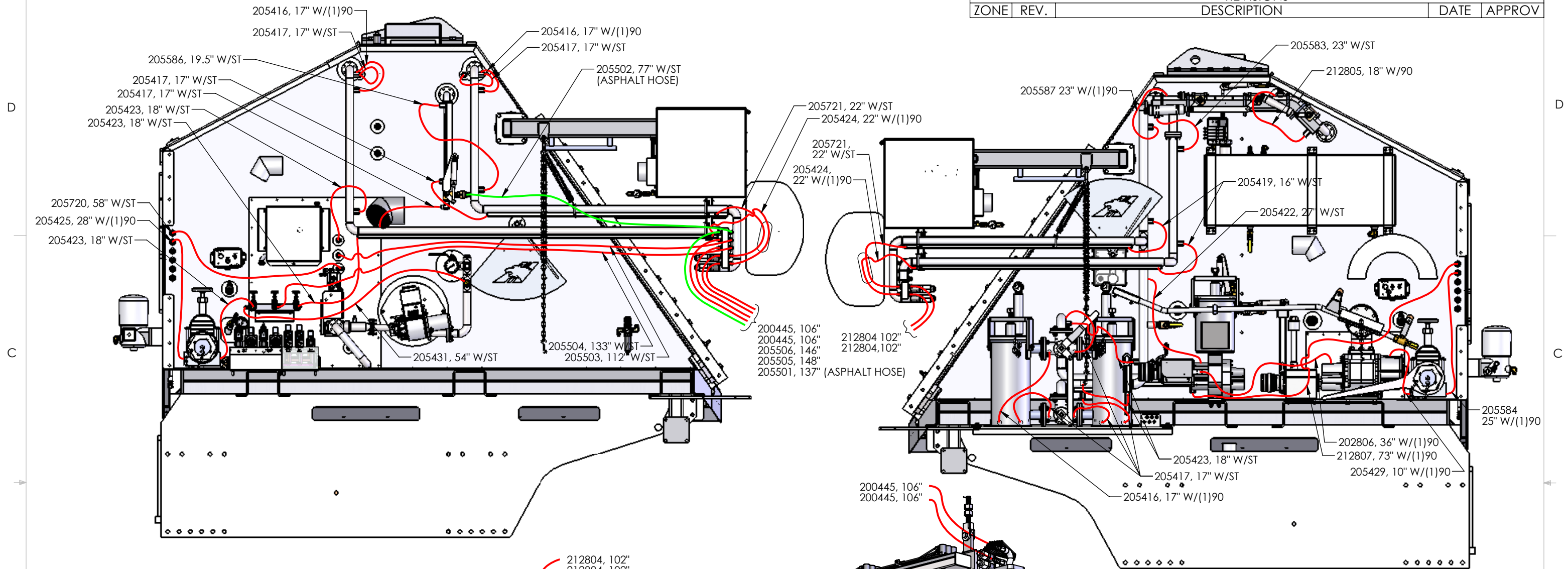

NO.	DESCRIPTION	QTY
200445	HOSE #36 FLX ASM S/S .50 X 106 IN HOT OIL PAN SP200	2
200450	HOSE #37 FLX ASM S/S .50 X 22 IN HOT 1-45 1-ST OIL PAN SP200	1
205416	HOSES #50-51-64 FLX ASM S/S .50 X 17 IN HOT OIL 1-ST-1 90 SP200	3
205417	HOSES #52-53-57-63-65-66-67 FLX ASM S/S .50 X 17 IN HOT OIL 2-ST	7
205419	HOSE #56 FLX ASM S/S .50 X 16 IN HOT OIL 2-ST SP200	1
205422	HOSE #61 FLX ASM S/S .50 X 27 IN HOT OIL 2-ST SP200	1
205423	HOSE #62 FLX ASM S/S .50 X 18 IN HOT OIL 2-ST SP200	1
205424	HOSE #68 FLX ASM S/S .50 X 22 IN HOT OIL 1-90 1-ST SP200	1
205425	HOSE #69 FLX ASM S/S .50 X 28 IN HOT OIL 1-90 1-ST SP200	2
205427	HOSE #48 FLX ASM S/S .50 X 88.5 IN HOT OIL PAN 2-ST SP200	1
205428	HOSE #47 FLX ASM S/S .50 X 85 IN HOT OIL PAN 2-ST SP200	1
205429	HOSE #76 FLX ASM S/S .50 X 10 IN LS LOAD VLV 1-ST 1-90 SP200	1
205430	HOSE #45 FLX ASM S/S .50 X 25 IN HOT OIL LS RTRN LOAD VLV 1-ML 1-ST SP200	2
205431	HOSE #44 FLX ASM S/S .50 X 54 IN HOT OIL 2-ST SP200	1
205501	HOSE #43 FLX ASM S/S .50 X 137 IN LNG ASPH RTRN PAN 2-ST SP200	1
205502	HOSE #42 FLX ASM S/S .50 X 77 IN LNG ASPH RTRN-MANF 2-ST SP200	1
205503	HOSE #41 FLX ASM S/S .50 X 112 IN LNG HOT OIL PAN 2-ST SP200	1
205504	HOSE #40 FLX ASM S/S .50 X 133 IN LNG HOT OIL PAN 2-ST SP200	1
205505	HOSE #39 FLX ASM S/S .50 X 148 IN LNG HOT OIL PAN-MANF 2-ST SP200	1
205506	HOSE #38 FLX ASM S/S .50 X 146 IN LNG HOT OIL PAN-MANF 2-ST SP200	1
205583	HOSE #55 FLEX ASM S/S .50 X 23 HOT OIL 2-ST SP200	1
205584	HOSE #71 FLEX ASM S/S .50 X 25 IN HOT OIL 1-90 1-ST SP200	1
205586	HOSE #73 FLEX ASM S/S .50 X 19 1/2 HOT OIL 2-ST SP200	1
205587	HOSE #74 FLEX ASM S/S .50 X 23 HOT OIL 1-90 1-ST SP200	1
205720	HOSE #77 FLX ASM S/S .50 X 58 IN HOT OIL 2-ST SP200	1
205721	HOSE #78 FLX ASM S/S .50 X 22 IN HOT OIL 2-ST SP200	1
212804	HOSE FLX ASM S/S .50 X 102 IN HOT OIL PAN SP200	2
212805	HOSE FLX ASM S/S .50 X 18 IN HOT OIL 1-ST 1-90 SP200	1
212806	HOSE FLX ASM S/S .50 X 36 IN HOT OIL 1-ST 1-90 SP200	1
212807	HOSE FLX ASM S/S .50 X 73 IN HOT OIL 1-ST 1-90 SP200	1

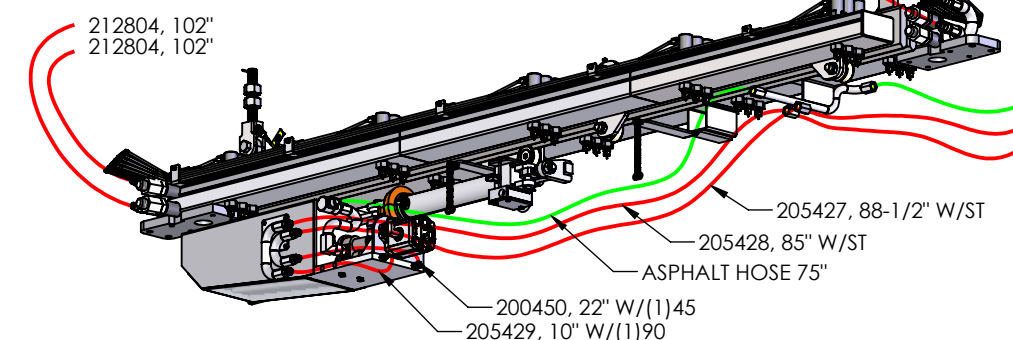

CONVERSION CHART	
1/16" = .0625	9/16" = .5625
1/8" = .125	5/8" = .625
3/16" = .1875	11/16" = .6875
1/4" = .250	3/4" = .750
5/16" = .3125	13/16" = .8125
3/8" = .375	7/8" = .875
7/16" = .4375	15/16" = .9375
1/2" = .50	1" = 1.00

BearCat Mfg.
PROPRIETARY AND CONFIDENTIAL
 THE INFORMATION CONTAINED IN THIS DRAWING IS THE SOLE PROPERTY OF BEARCAT MANUFACTURING. ANY REPRODUCTION IN PART OR AS A WHOLE WITHOUT THE WRITTEN PERMISSION OF BEARCAT MANUFACTURING IS PROHIBITED.

UNLESS OTHERWISE SPECIFIED:		NAME	DATE
DIMENSIONS ARE IN INCHES TOLERANCES: FRACTIONAL ± 1/32 ANGULAR: MACH ± 1.0° BEND ± TWO PLACE DECIMAL ± .02 THREE PLACE DECIMAL ± .003	DRAWN	JDC	10/6/14
	CHECKED		
	ENG APPR.	RTC	10/6/14
INTERPRET GEOMETRIC TOLERANCING PER: ANSI MATERIAL		DO NOT SCALE DRAWING	
FINISH	MAKE OR BUY:		M
N/A			

BEARCAT MFG.			
TITLE: SP200 HOT OIL HOISING DETAIL WITH PART NO. SER 110-NWR			
SP200			
SIZE	DWG. NO.	REV	
B	205451	REL	
SCALE: NONE	WEIGHT: 15504.13	SHEET 1 OF 2	

PAGE #1: HOT OIL HOISING & RETURN PAN ASPHALT 1/2" HOISING

PAGE #1: AIR HOISING, HYD HOISING & SPRAY BAR ASPHALT 1" HOISING

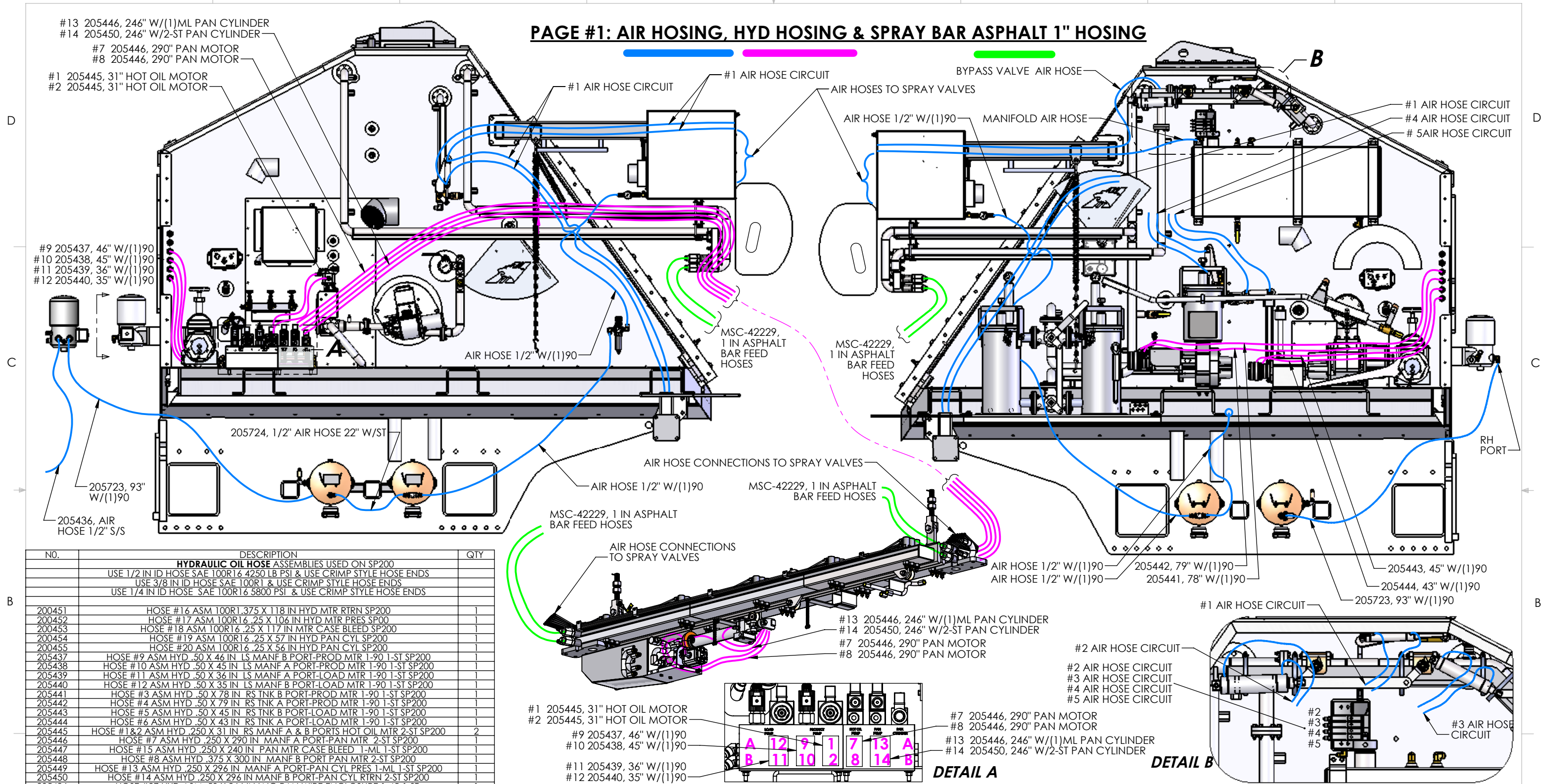

NO.	DESCRIPTION	QTY
HYDRAULIC OIL HOSE ASSEMBLIES USED ON SP200		
USE 1/2 IN ID HOSE SAE 100R16 4250 LB PSI & USE CRIMP STYLE HOSE ENDS		
USE 3/8 IN ID HOSE SAE 100R1 & USE CRIMP STYLE HOSE ENDS		
USE 1/4 IN ID HOSE SAE 100R16 5800 PSI & USE CRIMP STYLE HOSE ENDS		
200451	HOSE #16 ASM 100R1.375 X 118 IN HYD MTR RTRN SP200	1
200452	HOSE #17 ASM 100R16 .25 X 106 IN HYD MTR PRES SP00	1
200453	HOSE #18 ASM 100R16 .25 X 117 IN MTR CASE BLEED SP200	1
200454	HOSE #19 ASM 100R16 .25 X 57 IN HYD PAN CYL SP200	1
200455	HOSE #20 ASM 100R16 .25 X 56 IN HYD PAN CYL SP200	1
205437	HOSE #9 ASM HYD .50 X 46 IN LS MANF B PORT-PROD MTR 1-90 1-ST SP200	1
205438	HOSE #10 ASM HYD .50 X 45 IN LS MANF A PORT-PROD MTR 1-90 1-ST SP200	1
205439	HOSE #11 ASM HYD .50 X 36 IN LS MANF A PORT-LOAD MTR 1-90 1-ST SP200	1
205440	HOSE #12 ASM HYD .50 X 35 IN LS MANF B PORT-LOAD MTR 1-90 1-ST SP200	1
205441	HOSE #3 ASM HYD .50 X 78 IN RS TNK B PORT-PROD MTR 1-90 1-ST SP200	1
205442	HOSE #4 ASM HYD .50 X 79 IN RS TNK A PORT-PROD MTR 1-90 1-ST SP200	1
205443	HOSE #5 ASM HYD .50 X 45 IN RS TNK B PORT-LOAD MTR 1-90 1-ST SP200	1
205444	HOSE #6 ASM HYD .50 X 43 IN RS TNK A PORT-LOAD MTR 1-90 1-ST SP200	1
205445	HOSE #1&2 ASM HYD .250 X 31 IN RS MANF A & B PORTS HOT OIL MTR 2-ST SP200	2
205446	HOSE #7 ASM HYD .250 X 290 IN MANF A PORT-PAN MTR 2-ST SP200	1
205447	HOSE #15 ASM HYD .250 X 240 IN PAN MTR CASE BLEED 1-ML 1-ST SP200	1
205448	HOSE #8 ASM HYD .375 X 300 IN MANF B PORT PAN MTR 2-ST SP200	1
205449	HOSE #13 ASM HYD .250 X 296 IN MANF A PORT-PAN CYL PRES 1-ML 1-ST SP200	1
205450	HOSE #14 ASM HYD .250 X 296 IN MANF B PORT-PAN CYL RTRN 2-ST SP200	1
205496	HOSE #27 HYD ASM .50 X 266 IN LNG PAN WIRE ENCLOSURE 1-45-1-ST	1

ASPHALT BAR FEED HOSES ON SPRAY BAR SP200		
MSC-42229	(PURCHASED) HOSE 1IN X 99 IN ASPH 1.6FJX BARFEED SP200	4
1/2" AIR HOSE ASSEMBLIES ON PRESSURE TANKS TO VALVE BOXES & AUX. OUT		
USE 1/2 IN ID HOSE SAE 100R16 4250 LB PSI & USE CRIMP STYLE HOSE ENDS		
USE 1/2" TEFLOX LINED S/S BRAIDED HOSE TTRF115-10 & CRIMP STYLE FITTINGS		
205436	HOSE #26 FLEX ASM S/S .50 X 132 IN AIR HOSE-DRYER 2-ST	1
205723	HOSE ASM #21 AIR 100R16 .50 X 93 IN AIR DRYER 1-ST 1-90 SP200	1
205724	HOSE ASM #22 AIR 100R16 .50 X 20 IN AIR TNK JUMPER 1-ST 1-90 SP200	1
205725	HOSE ASM #23 AIR 100R16 .50 X 97 IN AIR TNK AIR SUPPLY 1-ST 1-90 SP200	1
1/4" AIR HOSE ASSEMBLIES TYP EXCEPT FOR AS NOTES ABOVE		
PIP-42173	USE 1/4 IN ID RUBBER BLACK 300 PSI -40/190 DEG NITRILE BUY ON ROLL CUT TO FIT	500 FT
FIT-42171	USE 1/4 IN FEMALE JIC 37 DEG BARBED 100 PUSH-ON FITTINGS	40
FAS-42174	CLAMP 2-EARS .50 ID PINCH TYPE SEAL	120

CONVERSION CHART			
1/16" = .0625	9/16" = .5625		
1/8" = .125	5/8" = .625		
3/16" = .1875	11/16" = .6875		
1/4" = .250	3/4" = .750		
5/16" = .3125	13/16" = .8125		
3/8" = .375	7/8" = .875		
7/16" = .4375	15/16" = .9375		
1/2" = .50	1" = 1.00		

BearCat Mfg.

PROPRIETARY AND CONFIDENTIAL
THE INFORMATION CONTAINED IN THIS DRAWING IS THE SOLE PROPERTY OF BEARCAT MANUFACTURING. ANY REPRODUCTION IN PART OR AS A WHOLE WITHOUT THE WRITTEN PERMISSION OF BEARCAT MANUFACTURING IS PROHIBITED.

UNLESS OTHERWISE SPECIFIED:		NAME	DATE
DIMENSIONS ARE IN INCHES		JDC	10/6/14
TOLERANCES:			
FRACTIONAL ± 1/32			
ANGULAR: MACH ± 1.0° BEND ± TWO PLACE DECIMAL ± .02		RTC	10/6/14
THREE PLACE DECIMAL ± .003			
INTERPRET GEOMETRIC TOLERANCING PER: ANSI MATERIAL		DO NOT SCALE DRAWING	
FINISH N/A		MAKE OR BUY: M	

BEARCAT MFG.

TITLE: SP200 HOT OIL HOISING DETAIL WITH PART NO. SER 110-NWR

SP200

SIZE **B** DWG. NO. **205451** REV **REL**

SCALE: NONE WEIGHT: 15504.13 SHEET 2 OF 2