

# THIS GROUND MUST GO TO GROUND STUD

NOTE:  
THESE FUSES MUST BE CHANGED TO 5 AMP WHEN A PROPANE IGNITOR SYSTEM IS USED. REPLACE FUSES AND ADD 5 AMP SPARES FOR NUMBER OF IGNITORS.

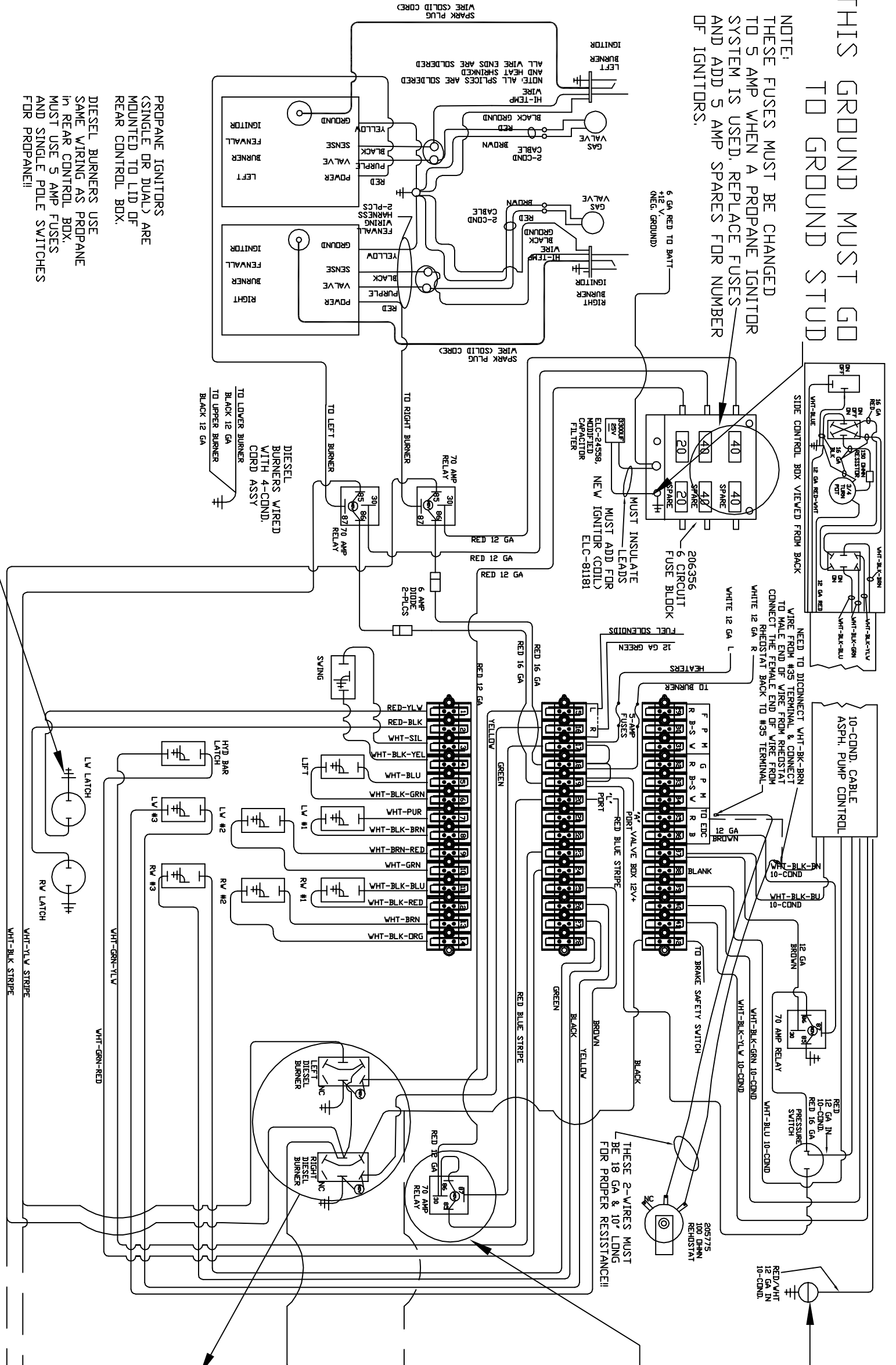

# GROUND STUD MUST BE WELDED TO INSURE GOOD CONNECTION

NOTE:  
MUST WIRE ALL 70 AMP RELAYS PER POST NUMBERS POST 86 IS (+) PLUS POLARITY

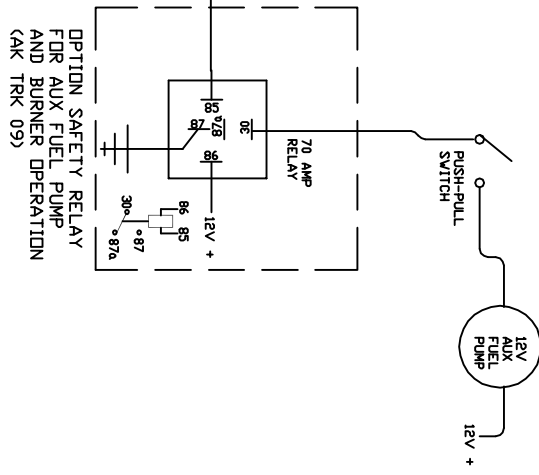

NOTE:  
THESE SINGLE POLE SWITCHES AND WIRING MUST BE INSTALLED WHEN PROPANE IGNITORS ARE BEING USED. RIGHT SWITCH IS ALWAYS WIRED TO SAFETY SWITCH.

ALL GROUNDS ARE JUMPED TOGETHER AND GROUNDED TO BOX GROUNDING STUD.

PROPANE IGNITORS (SINGLE OR DUAL) ARE MOUNTED TO LTD OF REAR CONTROL BOX.  
DIESEL BURNERS USE SAME WIRING AS PROPANE IN REAR CONTROL BOX. MUST USE 5 AMP FUSES AND SINGLE POLE SWITCHES FOR PROPANE!!

REV. ADDED SINGLE POLE SWITCHES AND 5 AMP FUSES TO BE WIRED WHEN USING PROPANE IGNITORS.  
RICK/FHK 3-15-11

REV. SWAPED BURNER RELAYS AND CIRCUIT BRKS 3-16-05 FHK/RICK  
REV. CHANGED 30 AMP BREAKERS TO 40 AMP & 50 AMP TO 20 AMP BREAKER FHK/RICK 9-29-08  
REV. ADDED PROPANE IGNITOR SCHEMATIC 11-15-07 FHK/RICK  
REV. ADDED SIDE CONTROL BOX WITH FWD/REVERSE SWITCH FHK/KH  
REV. ADDED HYD BAR LATCH SWITCH & WIRE FHK/RICK 5-14-09  
REV. ADDED AUX PUMP BURNER SAFETY SWITCH 7-29-09 RICK/FHK  
REV. CHANGED 70 AMP RELAY WIRING POST 86 IS POLARITY SENSITIVE (+) RICK/FHK 8-9-10  
REV. REMOVED ALL CIRCUIT BREAKERS ADDED 6 CIRCUIT FUSE BLDCK RICK/FHK 9-27-10

QTY	NEXT ASS'Y	MADE BY	BEARCAT
1	1111111111	APPROVED	
		MATERIAL	
		SEE PRINTED B.D.M.	
		DRAWING NO.	
		FINISH	
TITLE		REAR CONTROL BOX WIRING	
PART NO.		SERIAL SYSTEM 2011 NEWER	
		SCH-24027	
STANDARD		.X .XX .XXX .XXXX .ANG .X/X	
TOLERANCE		+.02 +.010 +.003 +.0005 +.1.0° +.1/32	
AUTHOR		JDC	
DATE		9-27-10	
SCALE		NONE	
SHEET		1 OF 1	



3650 SABIN BROWN  
RD. WICKENBURG,  
AZ 85390  
(928) 684-7851