

THIS GROUND MUST GO TO GROUND STUD

GROUND STUD MUST BE WELDED TO INSURE GOOD CONNECTION

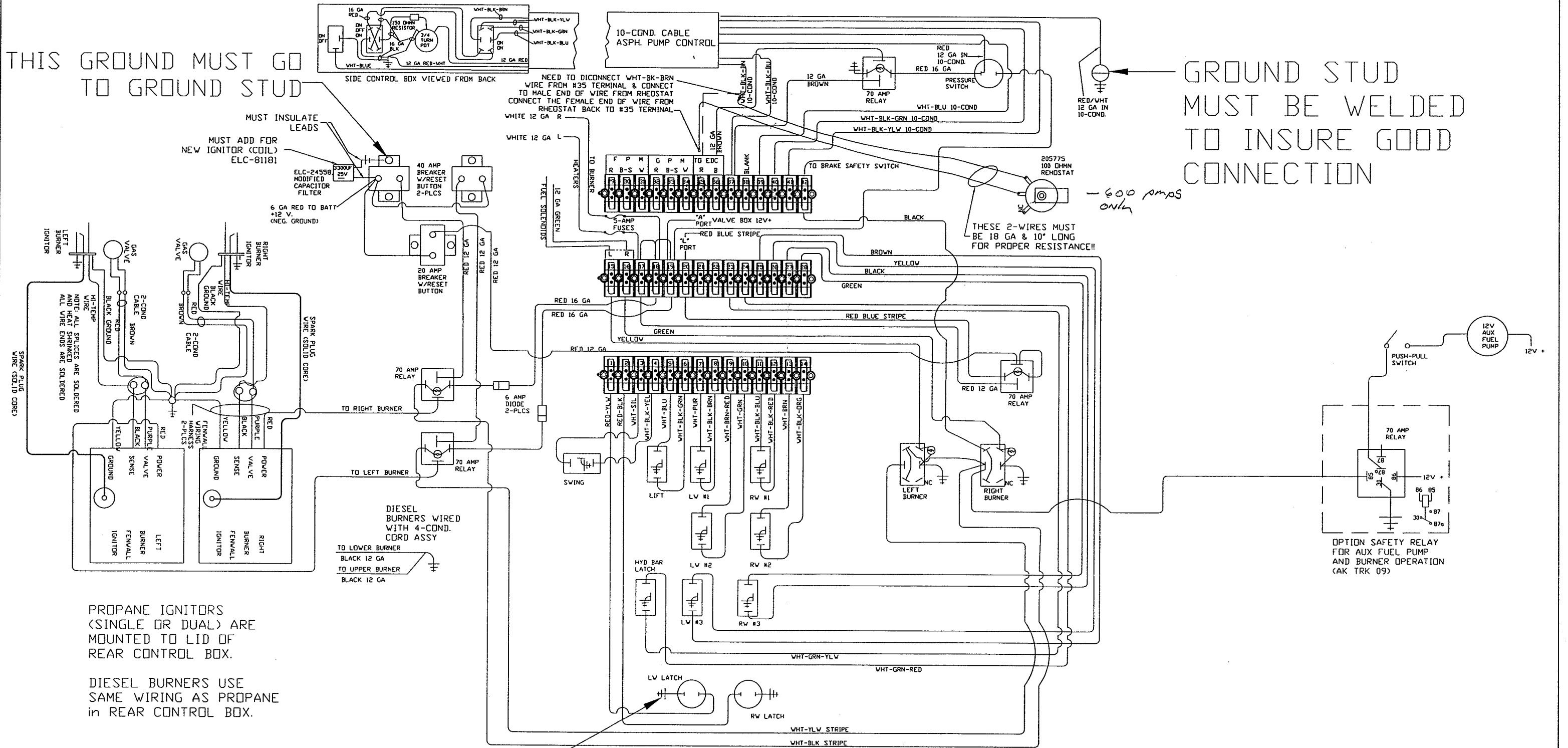

MUST INSULATE LEADS
MUST ADD FOR NEW IGNITOR (COIL) ELC-81181

NEED TO DISCONNECT WHT-BK-BRN WIRE FROM #35 TERMINAL & CONNECT TO MALE END OF WIRE FROM RHEOSTAT
CONNECT THE FEMALE END OF WIRE FROM RHEOSTAT BACK TO #35 TERMINAL

THESE 2-WIRES MUST BE 18 GA & 10\"/>

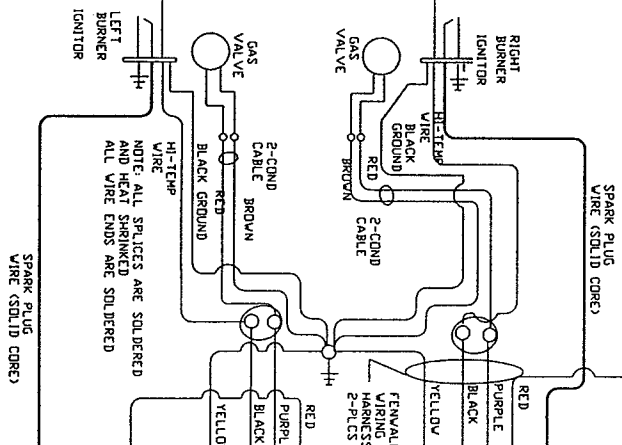

PROPANE IGNITORS (SINGLE OR DUAL) ARE MOUNTED TO LID OF REAR CONTROL BOX.

DIESEL BURNERS USE SAME WIRING AS PROPANE IN REAR CONTROL BOX.

ALL GROUNDS ARE JUMPED TOGETHER AND GROUNDED TO BOX GROUNDING STUD.

- REV: SWAPED BURNER RELAYS AND CIRCUIT BRKRS 3-16-05 FHK/RICK
- REV: CHANGED 30 AMP BREAKERS TO 40 AMP & 50 AMP TO 20 AMP BREAKER FHK/RICK 9-29-08
- REV: ADDED PROPANE IGNITOR SCHEMATIC 11-15-07 FHK/RICK
- REV: ADDED SIDE CONTROL BOX WITH FWD/REVERSE SWITCH FHK/KH
- REV: ADDED HYD BAR LATCH SWITCH & WIRE FHK/RICK 5-14-09
- REV: ADDED AUX PUMP BURNER SAFETY SWITCH 7-29-09 RICK/FHK

QTY	NEXT ASS'Y	MADE BY	BEARCAT
?	---	APPROVED	
		MATERIAL	
		SEE PRINTED B.O.M.	
	FINAL ASS'Y		
?	---	DRAWING NO.	
		FINISH	



3650 SABIN BROWN RD. WICKENBURG, AZ 85390 (928) 684-7851

BEARCAT MFG.

TITLE
REAR CONTROL BOX WIRING
SERIAL SYSTEM 2009-NEWER

PART NO.
SCH-24029

STANDARD TOLERANCE	.X +.02	.XX +.010	.XXX +.003	XXXX +.0005	ANG. +1.0°	X/X +1/32	AUTHOR JDC	DATE 3/26/10
							SCALE NONE	SHEET 1 OF 1