

12VDC ACC (RED-WHT) C2-P12
12VDC ACC (RED-WHT) C2-P12
24Vdc POWER SUPPLY
12VDC ACC (RED-WHT) C2-P12
24VDC (BRN-WHT) T4

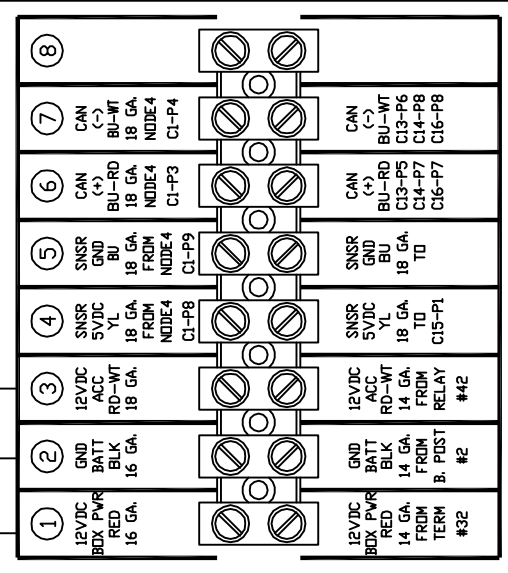
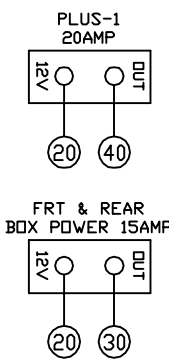
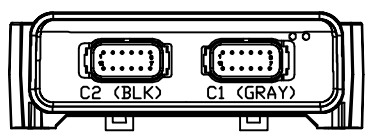

12VDC ACC (RED-WHT) C1-P2
12VDC ACC (RED-WHT) C2-P11
12VDC ACC (RED-WHT) C2-P12

GROUND (BLK) C1-P1

12VDC BOX PWR (RED) C13-P3
12VDC BOX PWR (RED) C13-P4
12VDC BOX PWR (RED) C16-P3
12VDC BOX PWR (RED) C16-P4

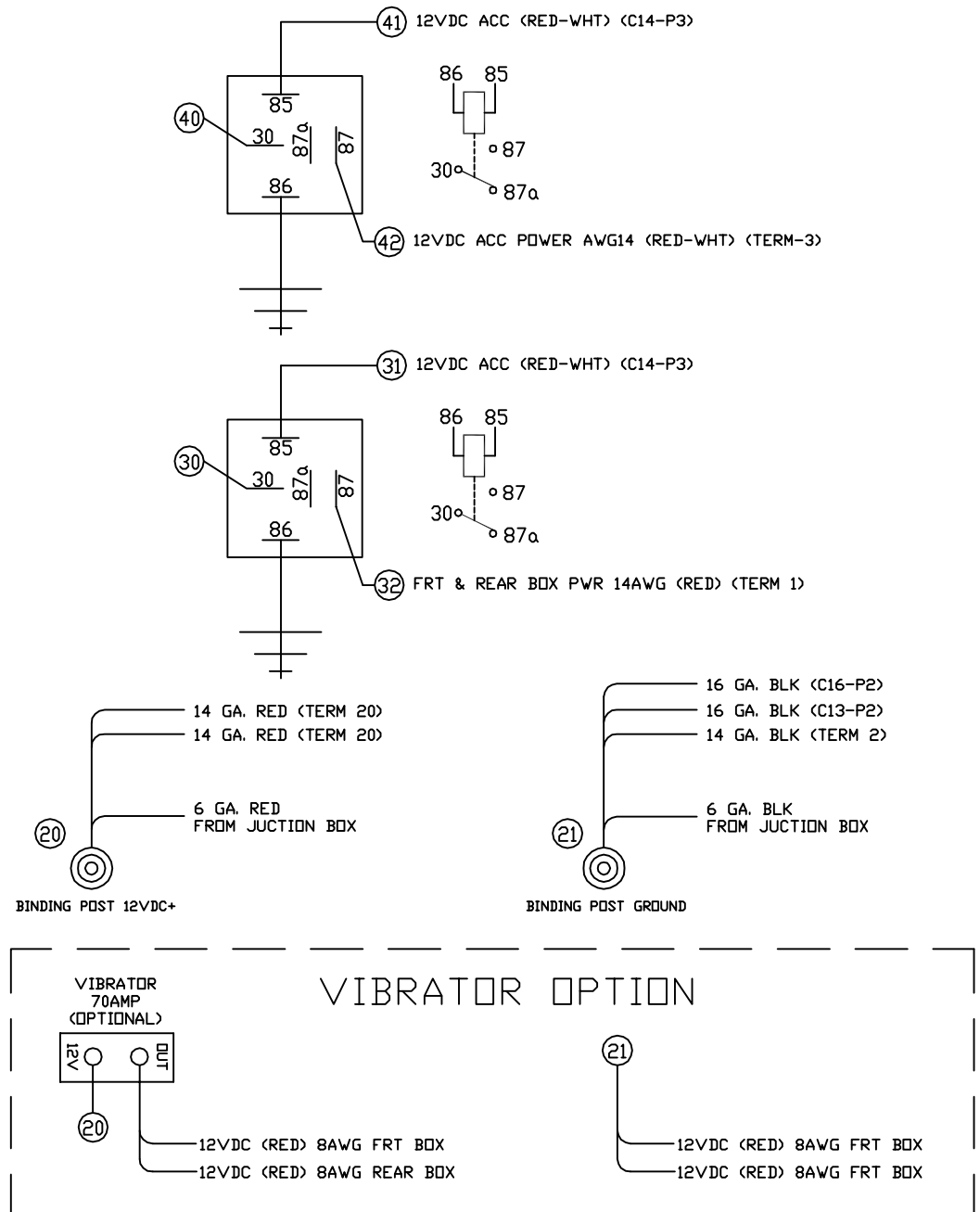
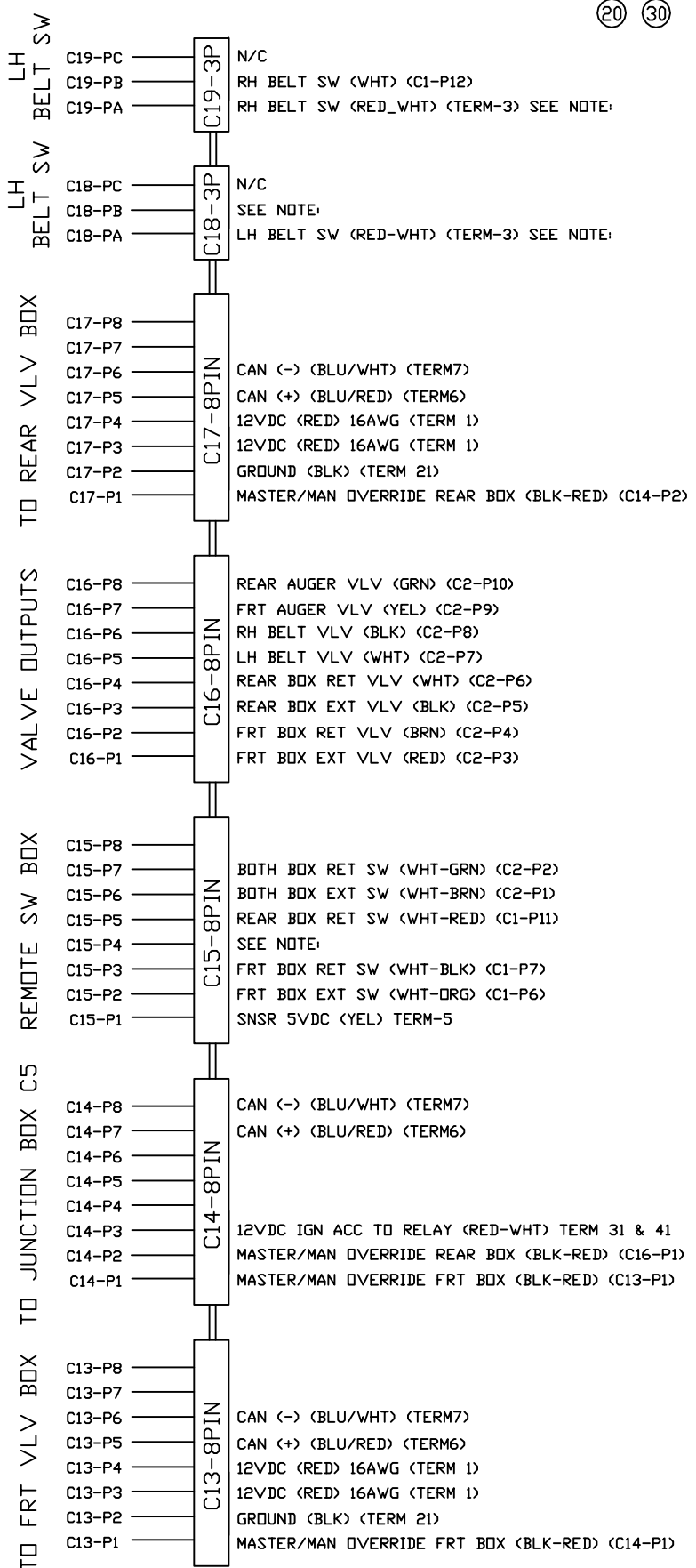

NOTE:
SOFTWARE EARLIER THAN V2.0
LH BELT SW (WHT) (C1-P5)
REAR BOX EXT SW (WHT-SIL) (C1-P10)

SOFTWARE V2.0 AND LATER
LH BELT SW (WHT) (C1-P10)
REAR BOX EXT SW (WHT-SIL) (C1-P5)

ALSO V2.0 & LATER SENSOR POWER
IS 24Vdc FROM POWER SUPPLY TERM3
EARLIER MODELS USED 5VDC (YEL)

DWG #200800
7/30/2007
WIRING DETAIL 2007 CHIPPER
SCHE ELC WIRE PLUS1
TANDEM SLAVE BOX CHIP